

NJEX 6300G

NATURAL GAS ODORIZATION SYSTEM

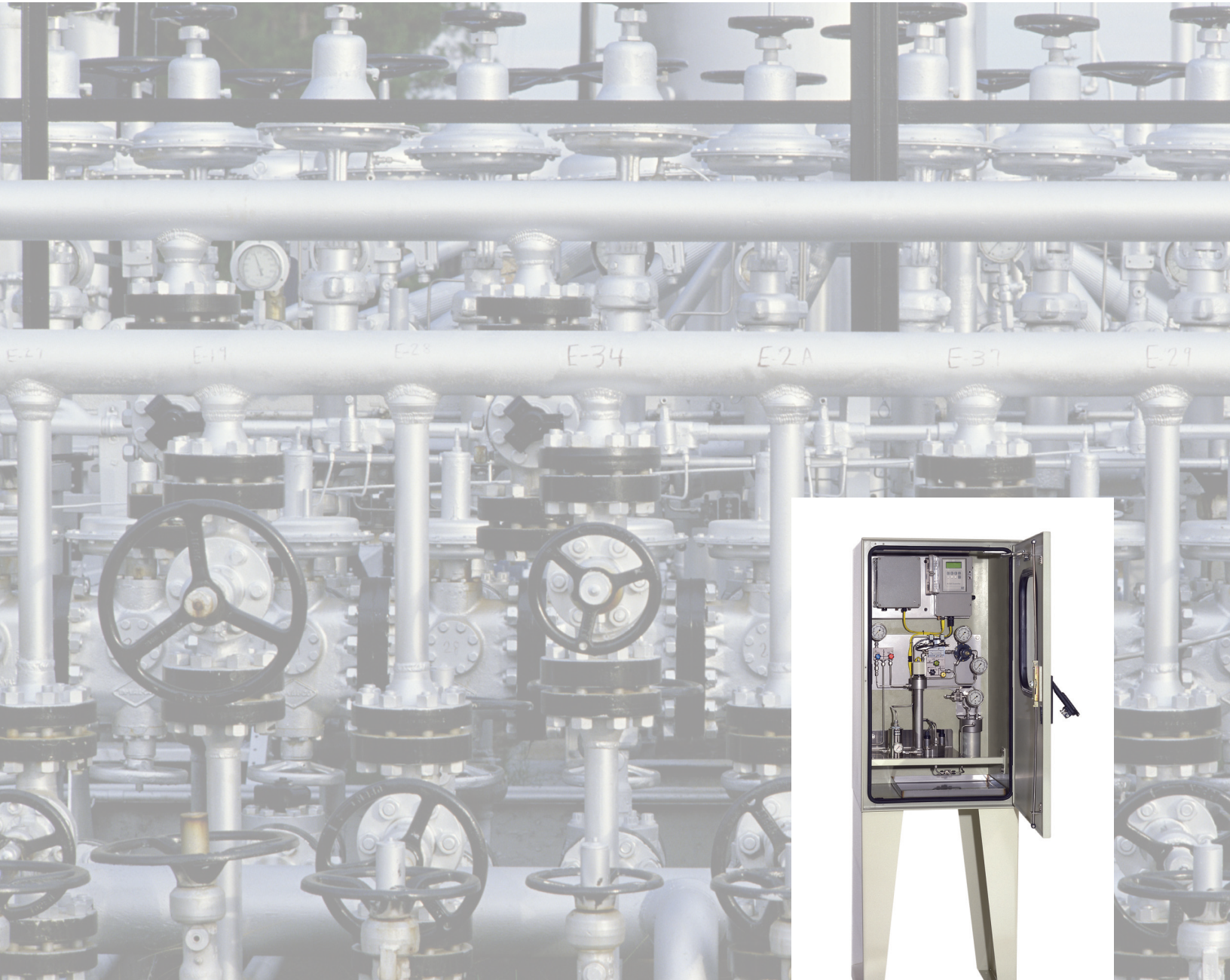

6300G TABLE OF CONTENTS

6300G Table of Contents.....	I
Section 1: First Things To Know About The 7300G	1
How to Use this Manual.....	1
Typographic Conventions	1
Getting Help.....	1
Operation Specifications.....	2
Warranty	visit: www.yzsystems.com
Theory of Operation.....	3
System Accessories	3
Section 2: System Installation.....	5
Standard System Components.....	5
System Flow Schematic	6
Standard System Mounting	7
Standard System Connections	8
Skid System Components	10
System Flow Schematic	12
Skid System Mounting.....	13
Skid System Connections.....	14
Section 3: Filling the Bulk Odorant Tank	17
Filling the Tank for the First Time.....	17
Refilling the Bulk Odorant Tank	18
Section 4: System Control & Electronics.....	19
Overview.....	19
To Use The Key Pad.....	19
To Power Up The System.....	20
Test & Standby Keys	21
Battery & Solar Panel Assembly.....	22
LPS and Battery w/Cover Removed.....	22
Solar Panel.....	22
SPS and Battery w/Cover Removed	22
Communications Interface.....	23
Comm-Link Configuration.....	23

6300G TABLE OF CONTENTS

Section 5: Programming for Proportional-to-Flow Operation	25
Setting Operator Input Parameters.....	25
Odorant injection rate in lbs/MMCF (mg/m3) of gas.....	25
Pump displacement in cc/stroke.....	25
Odorant density in lbs/gallon (g/cc) @ 60° F.....	25
Max gas flow in MMCF/Hour (m3/sec).....	26
Low Flow Shut Off.....	26
Flow (no signal) input.....	26
Maximum Time/Stroke.....	27
The Odorant Output Setting.....	27
Odorant Tank.....	28
Expansion Tank Pressure Monitoring.....	28
Odorant Inlet Pressure Monitoring.....	29
Alarm to Relay Delay.....	30
Alarm to Call Out Delay.....	30
MODBUS Address.....	30
MODBUS Parameters.....	31
Conclusion.....	31
Section 6: Programming for Proportional-to-Time Operation	33
Setting Operator Input Parameters.....	33
Pump displacement in cc/stroke.....	33
Odorant density in lbs/gallon (g/cc.) @ 60°F.....	33
Time interval between strokes of the pump in xx.xx minutes/stroke:.....	33
The Odorant Output Setting.....	34
Odorant Tank.....	34
Expansion Tank Pressure Monitoring.....	35
Odorant Inlet Pressure Monitoring.....	35
Alarm to Relay Delay.....	36
Alarm to Call Out Delay.....	36
MODBUS Address.....	37
MODBUS Parameters.....	37
Conclusion.....	38
Section 7: Calibrating Signal Inputs	39
Analog Flow Input Calibration, 1-5 VDC / 4-20 mA.....	39
Expansion Tank Pressure Transmitter Zero Calibration.....	41
Odorant Inlet Pressure Transmitter Zero Calibration.....	42
Pulse Flow Input Calibration, Dry Contact & Voltage Pulse.....	44
Calculation for Determining the Span Frequency Example.....	45

6300G TABLE OF CONTENTS

Section 8: Working with the N-300 System Displays	47
Display Functionality	47
To View Real Time Displays	48
Strokes Signaled	48
Odorant Injected	48
Pump Displacement	48
Pump Alarms	48
Meter Level – Verometer	49
Meter Alarms – Verometer	49
Meter Indicators, non-alarm	49
Expansion Tank	50
Odorant Inlet	50
Battery Voltage	50
Battery Alarm	50
Flow Input	50
Flow Input Alarms	50
Flow Input Indicators, non-alarm	50
Tank Level	51
Tank Level Alarm	51
Odorant Temperature	51
Section 9: Setting & Testing Alarms	53
Setting Alarm Out Status	53
Testing Alarm Out Status	55
Setting The Clock	58
Section 10: Mechanical System	61
Overview	61
Odorant Inlet Manifold & Bulk Odorant Filter Assembly	62
Fill Valve	62
Verometer	63
Model 7000F Pump	64
Odorant Discharge Manifold	64
NJEX Gas Filter	65
Solenoid Valve & Pneumatic Relay Manifold	66
Expansion Tank	66
Section 11: System Operation	67
Setting System Pressures and Valves	67
Low Pressure Relief Adjustment	67
Starting The System	68
To Stop The System	69

6300G TABLE OF CONTENTS

Section 12: System Maintenance	71
Preventative Maintenance Schedule.....	71
Recommended Maintenance Schedule.....	71
Weekly Inspection.....	71
Semi-Annual Inspection.....	71
Annual Inspection.....	71
Bi-Annual Inspection.....	71
Recommended Spare Parts List.....	71
Overflow Protector Assembly Inspection.....	72
Low Pressure Relief Adjustment.....	73
Conducting a Forward Purge.....	74
Venting Pressure Gas.....	76
Filling the Verometer.....	78
Priming & Starting the NJEX System.....	80
Section 13: 7300G System Troubleshooting	83
How to Use This Section.....	83
For Additional Help.....	83
Step-by-Step Resolution.....	83
Tank Level Alarms.....	83
Tank Level Alarm Troubleshooting Steps.....	84
Battery Alarm.....	84
Battery Alarm Troubleshooting Steps.....	84
Signal Alarms.....	85
Signal Non-Alarm Indicators.....	85
Signal Alarm & Non-Alarm Indicator Troubleshooting Steps.....	85
Loss of Flow Alarm Troubleshooting Steps.....	85
Overflow Alarm Troubleshooting Steps.....	85
Low Flow Non-Alarm Indicator Troubleshooting Steps.....	86
Overflow Non-Alarm Indicator Troubleshooting Steps.....	86
Verometer Alarms.....	86
Verometer Non-Alarm Indicators.....	87
Verometer Troubleshooting Steps.....	87
Verometer Cable Alarm Troubleshooting Steps.....	87
Verometer No-Fill Alarm Troubleshooting Steps.....	87
Verometer Slow-Fill Alarm Troubleshooting Steps.....	88
Verometer Leakage Alarm Troubleshooting Steps.....	88
Verometer Fill Valve Failure Alarm Troubleshooting Steps.....	89
Verometer Odorant Inlet Cable Alarm Troubleshooting Steps.....	89
Verometer Odorant Inlet Low Alarm Troubleshooting Steps.....	90
Verometer Odorant Inlet Hi Alarm Troubleshooting Steps.....	90
Verometer Expansion Tank Cable Alarm Troubleshooting Steps.....	90
Verometer Expansion Tank Low Alarm Troubleshooting Steps.....	90
Verometer Expansion Tank High Alarm Troubleshooting Steps.....	91
Verometer Overfill Non-Alarm Indicator Troubleshooting Steps.....	91
Verometer Fill Rate Non-Alarm Indicator Troubleshooting Steps.....	91

6300G TABLE OF CONTENTS

Section 13: 7300G System Troubleshooting continued

Pump Alarms	91
Pump Over Pumping Alarm Troubleshooting Steps	92
Pump Under Pumping Alarm Troubleshooting Steps	92
Pump Failure Alarm Troubleshooting Steps	93

Appendix A: Illustrations 95

NJEX Model 7000F Pump Assembled	95
NJEX Model 7000F Pump Actuation Assembly, Exploded View	96
NJEX Model 7000F Pump, Diaphragm Cartridge, Exploded View	97
NJEX Model 7000F Pump, Check Valve Assembly, Exploded View	98
Fill Valve, Exploded View	99
VM-1100 Verometer, with Filter Assembly, Exploded View	100
Bulk Odorant Filter	101
NJEX Gas Filter	102
Electronics Assembly	103
SPS-12 Solar Power Supply Unit	104
LPS-120/240 Charger Supply Unit	105
Heater Wiring Diagram	106

Appendix B: N-300 Modbus Specifications 107

Communications Settings	107
N300 Modbus Function Support	107
Boolean Registers	107
Control Functions	107
Status Functions	108
Alarm Functions	109
Integer Registers	110
Result Data Functions	110
Parameter functions	112
Exception Responses	112

Appendix C: Response Forms 113

For the Record Form	113
NJEX Trouble Shooting Form	114

Appendix D: Documents 115

N-300 Controller Display Diagram	115
Wiring Control Document	116

Appendix E: N-300 ATEX Connections 117

SECTION 1: FIRST THINGS TO KNOW ABOUT THE 6300G

How to Use this Manual

The NJEX-6300G Operations Manual is a step-by-step guide containing the procedures needed to work with the 6300G System.

The NJEX System Series of odorizers implement the most advanced technology available in the industry. It is recommended that the technicians working with the NJEX Odorization Systems study the manual prior to initiating work on the system for the first time.

Typographic Conventions

To aid in readability, this manual uses several typographic conventions. References to illustrations, photographs, and other related content will appear in *italicized text* along with the location of where to find the item in the manual. Digital versions of the manual, available in Adobe Acrobat™ PDF format, will be highlighted further in *blue italic text* indicating the copy retains a hyperlink to the referenced item.

Measurement units are listed in italic parenthesis text following their US standard equivalent. As an example, for defining a distance, 15' (*4.5 meters*), is how the text will appear throughout the manual.

Items that require action, for example the pressing of a key for programming the controller, will feature the action item in sentence case **Bold Text** followed in normal text by the item such as, the **Up Arrow** key or **Main Power** switch.

Starting with Section 4, System Control & Electronics, the manual will begin discussing the in-depth operation of the N-300 electronic controller where many of these typographic conventions will be found. In the discussion about the controller, the technician will learn about the dual-use keypad. Here, the controller LCD will display a new function for the key located immediately below the displayed item. For example, an **Up Arrow** key may have ***Set** immediately above it on the LCD indicating to set, or enter, the selected item into the memory of the N-300 controller. The asterisk (*), immediately before **Set** on the LCD indicates the dual-use keypad is active. Further discussion on the dual-use capability of the N-300 controller keypad will take place in [Section 4, System Control and Electronics, on page 19](#).

Getting Help

This manual provides solutions to typical questions about the 6300G system. If the answer can not be found within this manual, contact YZ Systems at:

T: 1.281.362.6500
T: 1.800.653.9435 (*800.NJEX.HELP*)
F: 1.281.362.6513
Em: TechSupport@yzhq.com

When calling, have this manual close at hand. Whether calling or writing, please include in your communicate the following information:

- The serial number of the NJEX System and the version number of this manual. The serial number is located on the inside of the enclosure door just below the system flow diagram. The version number of this manual is located at the bottom of each page.
- A description of the problem and, if applicable the actions of the technical personnel when the problem occurred.
- A listing of any messages that may have appeared in the LCD on the N-300G controller, please include:
 1. The exact wording of the message(s).
 2. The version number of the Sentry software

SECTION 1: FIRST THINGS TO KNOW ABOUT THE 6300G

used.

Operation Specifications

Maximum Odorant Output:	1.76 gallons/day (6.7 liters/day)
Maximum Operating Pressure:	1,440 psig (99.28 Bar (g))
Operating Temp Range:	0 to 140 degrees F. (17°C to 60°C)
Power Supply:	SPS-12 solar panel , std. LPS-120/240 volt- 50/60Hz AC charger, opt.
Battery Reserve ¹ :	Approximately 30 days
Gas Flow Rate Input Signal:	1-5 VDC, 4-20 mA or pulse

Note: at temperatures below 32° F (0° C), conditioning of the actuation gas supply may be required. Where the actuation gas supply has a high water content and/or a low hydrocarbon dew point, additional actuation gas filtration or heating of the actuation gas supply may be necessary. Bottled nitrogen can also be used during cold operating conditions to avoid condensation in the actuation gas supply line. In addition, operation at extreme temperatures will affect seal and diaphragm performance. To prolong the service of seals and diaphragm, adequate heat should be provided to maintain an operating environment above 30° F (-1° C).

NJEX Systems are approved Class I, Div I and must be installed grounded, wired and I.S. Barrier Protected in accordance with all applicable electrical codes.

Warranty

Please visit our web site www.yzsystems.com for a complete copy of our warranty contained in our Terms and Agreement document.

¹ Actual reserve time is dependant on age and condition of battery and the usage rate of the NJEX System.

SECTION 1: FIRST THINGS TO KNOW ABOUT THE 6300G

Theory of Operation

Operation of the 6300G centers around three primary components: the Model 6000 pump, the Model VM-1000 Verometer and the Model N-300G controller.

During normal operation, the Model 6000 pump injects an exact quantity of odorant at a rate determined by the N-300G controller. The quantity of odorant injected per stroke is set using a spacer in the pump actuation assembly. The rate at which the pump is actuated is determined by the N-300G controller.

The VM-1000 Verometer serves as a temperature compensated meter which verifies the amount of odorant injected by the Model 6000 pump. The N-300G controller uses an input signal from the Verometer to determine the amount of odorant that has been injected, as well as the odorant level within the Verometer. Once the odorant level falls to a predetermined low level point, the N-300G controller actuates a solenoid valve which opens the fill valve, allowing the Verometer to be refilled. Once the Verometer is filled, the N-300G controller closes the fill valve.

The N-300G controller allows the 6300G system to operate in either a time-based mode or a proportional-to-flow mode. In the time-based mode of operation, the N-300G controller actuates the Model 6000 pump at a regular time interval preset by the operator.

In the proportional-to-flow mode of operation, the N-300G controller uses a customer provided gas flow rate input signal and several operator input values to calculate the time between strokes of the pump. These operator input values include the odorant injection rate (*lbs/MMCF or mg/m³*), pump displacement (*cc/stroke*), and the odorant density (*lbs/gal or g/cc*). The flow input signal is customer provided by either a flow computer or other flow monitoring devices. In this mode, the controller has the capability to distinguish between a low flow situation and a loss of flow input signal. For systems with analog inputs, if a loss of flow signal occurs, the controller automatically defaults back to a pre-selected percentage of the flow input.

The flow input signal is read by the N-300G controller eight times per pump stroke. These readings are averaged and the time duration until the next stroke is then calculated by the controller. The maximum time between strokes is

99.99 minutes (when gas is flowing), regardless of the time calculated by the controller.

CAUTION:

Excessive tubing lengths should be avoided. Installation of the NJEX Odorization system should be as close to the point of injection and Odorant Storage Tank as possible. Maximum tubing length should not exceed 15' (4.5 meters) with the tubing size maintained as indicated in this manual. If longer tubing lengths are required consult YZ Systems Technical Services at; 800.653.9435 or 1.281.362.6500.

System Accessories

- **Odorant Injection Probe**, includes a 316 stainless steel probe, and isolation valve for location at the pipeline. When ordering, please specify pipeline connection required, 1/2" or 3/4".
- **Odorant Injection Probe with Sightglass**, includes a 316 stainless steel probe, visual odorant sight indicator, and an isolation valve for location at the pipeline. When ordering, please specify pipeline connection required, 1/2" or 3/4".
- 1/4" stainless steel discharge tubing **In-line Check Valve**. For placement in the odorant discharged tubing line immediately preceding the probe assembly, (P/N A3-0024).
- 1/4" stainless steel tubing **Dielectric Isolator Union**. These should be installed in every tubing line that attaches the odorizer to the pipeline in any manner. For example the supply gas, odorant discharge, and differential pressure switch connections, (P/N A1-0182).
- **NJEX Scrubbers**. These filters are designed to scrub the exhaust gas vented from the pumps or Overflow Protector of the Expansion Tank. They are available by ordering P/N C4-0018, 15 gallon scrubber.

A complete line of odorization accessories ranging from pre-odorized gas scrubbers to injection probes is available through YZ. Please contact your local representative or YZ toll free at 800.344.5399. For technical support call 800.653.9435.

SECTION 2: SYSTEM INSTALLATION

Standard System Components

Standard primary components of the NJEX-6300G include the following:

- **System Enclosure**, *figure 1*. Houses the Model 6000 pump, the Model VM-1000 Verometer, the odorant fill valve, the solenoid valve/pneumatic relay manifold, the odorant discharge manifold, the system control enclosure, power supply enclosure, and bulk odorant filter.
- ***SPS12 Solar Panel Assembly**, *figure 1*. The standard solar panel for the 6300G is equipped with a mounting bracket and a connection cable. Optional LPS-120/240 may be used in lieu of the solar panel.
- **System Control Enclosure**. Houses the N-300G controller. (Not illustrated)
- ***Power Supply Enclosure**. Houses the battery, charger supply, and I.S. Barrier. (Not illustrated)
- **Bulk Odorant Filter**, *figure 3*. Provides primary odorant filtration between the storage tank and the NJEX-6300G. The Bulk Odorant Filter is pre-installed inside the System Enclosure attachment to the odorant source is via an odorant inlet manifold equipped with 1/4" FNPT connection located on the back of the System Enclosure.
- **Service Tray**, (*Not Illustrated*), should be installed in the bottom of the system enclosure, to capture any drops that may occur during servicing of the odorizer.
- **Mechanical Cabinet Cable**, *figure 3*. Provides the connection between the system control enclosure and the electrical components in the mechanical section.
- **Expansion Tank**, *figure 2*. Provides a closed loop system for pressure fluctuations within the Verometer during the odorant fill/injection cycle.
- **NJEX Gas Filter**, *figure 2*. Installed between the actuation gas regulator and the actuation gas manifolds, this filter provides a 25 micron coalescent filtration to insure a clean pneumatic supply.
- **Actuation Gas Regulator**, *figure 3*. Provides additional regulation of supply gas to actuate the pump.

- **SPS12 Solar Panel Assembly**



Figure 1



Figure 2

Actuation Gas Regulator



Figure 3

* ATEX installations refer to Appendix E, page 117.

SECTION 2: SYSTEM INSTALLATION

System Flow Schematic

Figure 4

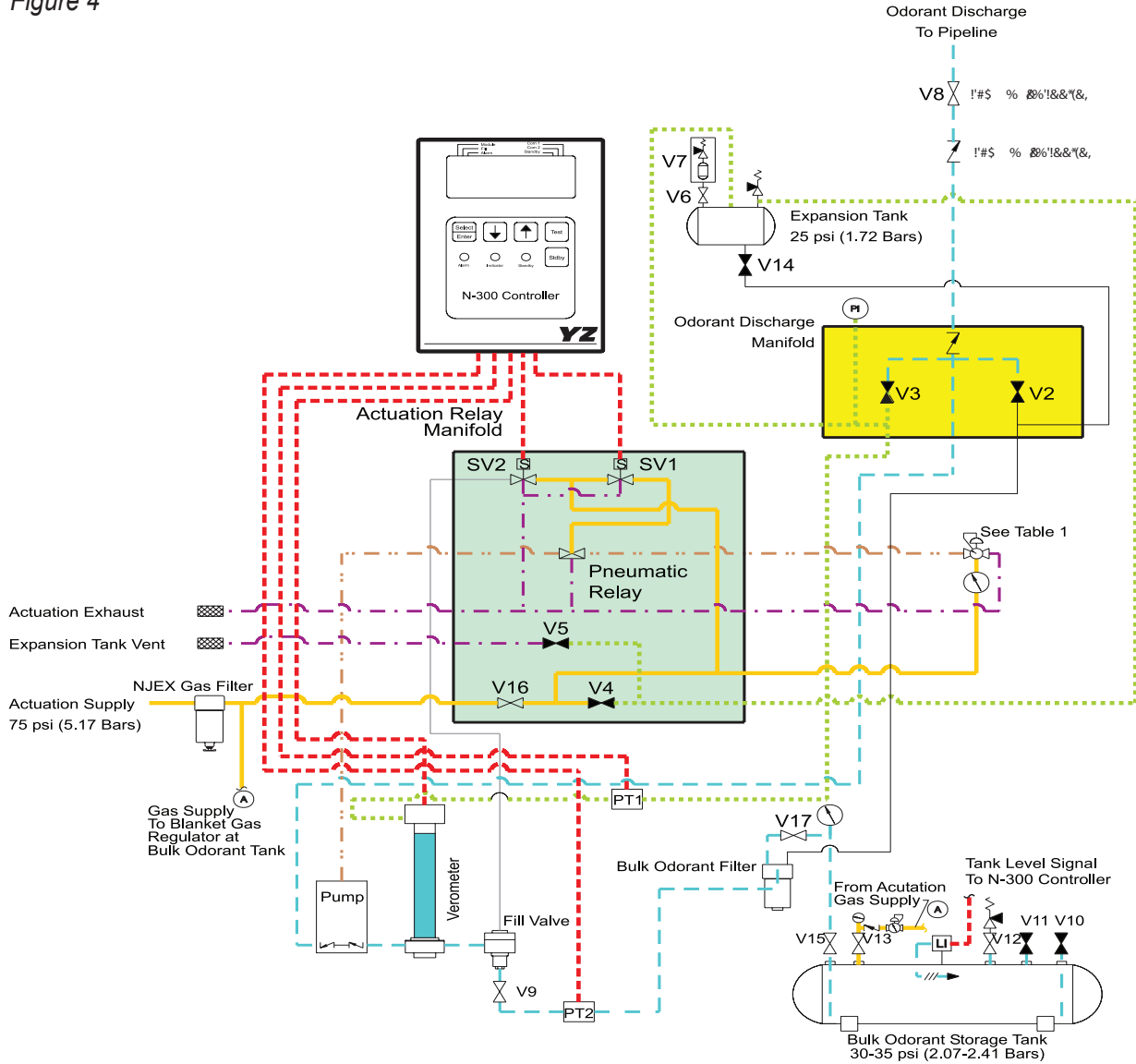

Pipeline Pressure	Actuation Pressure
100-200 psi (6.89-13.8 Bar)	30 psi (2.07 Bar)
200-500 psi (13.89-34.5 Bar)	40 psi (2.76 Bar)
500-900 psi (34.5-62.1 Bar)	50 psi (3.45 Bar)
900-1400 psi (62.1-96.5 Bar)	60 psi (4.14 Bar)

IMPORTANT: Read And Follow Steps 1-4 BEFORE Proceeding

- Place the controller in the "standby" mode.
- Close all valves marked "X".
- Open all valves marked "O".
- Place controller in the proper mode of operation as needed.

Open to build pressure to 60 psi (4.14 Bars) then close valve
 * - Adjust as needed

	V2	V3	V4	V5	V6	V8	V9	V10	V11	V12	V13	V14	V15	V16	V17
Normal Operation	X	X	X	X	O	O	*	X	X	O	O	X	O	O	O
System Purge	O	X	X	X	X	X	*	X	X	O	O	X	O	O	O
System Vent	O	O	X	O	X	X	*	X	X	O	O	X	O	O	X
Leak Test	O	O	O	X	X	X	*	X	X	O	O	X	O	O	X
Prime Pump	X	O	X	X	O	X	*	X	X	O	O	X	O	O	O

LEGEND

- | | | | | | | | | | |
|--|------------------------------|--|------------------------------------|-----|---|-----|--|-----|------------------------------------|
| | Normally Closed Valve | | Liquid Odorant - Normal Operation | V2 | Purge Valve (Red Knob) | V11 | Odorant Storage Tank Vapor Return Valve | SV2 | Fill Valve |
| | Normally Open Valve | | Purge/Drain Line | V3 | Prime Valve (Blue Knob) | V12 | Odorant Storage Tank Pressure Supply Valve | PT1 | Expansion Tank Solenoid Valve |
| | Pneumatic Relay | | Expansion Line | V4 | Expansion Tank Pressure Supply Valve (Gold Knob) | V13 | Odorant Storage Tank Blanket Gas Isolation Valve | PT2 | Odorant Inlet Pressure Transmitter |
| | Check Valve | | Intrinsically Safe Electrical Line | V5 | Expansion Tank Vent Valve (Green Knob) | V14 | Expansion Tank Drain Valve | | |
| | Float Valve | | Exhaust/Vent Line | V6 | Expansion Tank Overflow Preventor Isolation Valve | V15 | Odorant Storage Tank Supply Isolation Valve | | |
| | Pressure Gauge | | Actuation Line 75 psi (520 Kpa) | V7 | Expansion Tank Overflow Preventor | V16 | Gas Supply Isolation Valve (Black Knob) | | |
| | Electronic Level Transmitter | | Fill Valve Actuation Line | V8 | Isolation Valve | V17 | System Odorant Supply Isolation Valve | | |
| | Solenoid Valve | | Pump Actuation Line | V9 | Fill Rate Control Valve | SV1 | Pump Actuation Pilot Solenoid Valve | | |
| | Pressure Regulator w/Gauge | | | V10 | Odorant Storage Tank Fill Valve | | | | |
| | Pressure Relief Valve | | | | | | | | |
| | Pressure Transmitter | | | | | | | | |

SECTION 2: SYSTEM INSTALLATION

Standard System Mounting

Figure 5

1. Bolt down the system enclosure to a concrete slab using the mounting holes (9/16") provided in the bottom of each leg of the enclosure. Recommended bolt/stud sizes for mounting the enclosure is 1/2".
2. In order to satisfy NEC requirements you must connect a ground wire from the grounding lug located on the enclosure leg to a properly installed ground rod, located adjacent to the system enclosure. *Resistance to ground must be less than 1 Ohm. To assure proper system operation this ground should not be a shared ground with any other equipment.

TABLE			
	A	B	C
SINGLE	20-3/4"	20-1/4"	9"
DUAL	40-1/4"	39-1/2"	9"

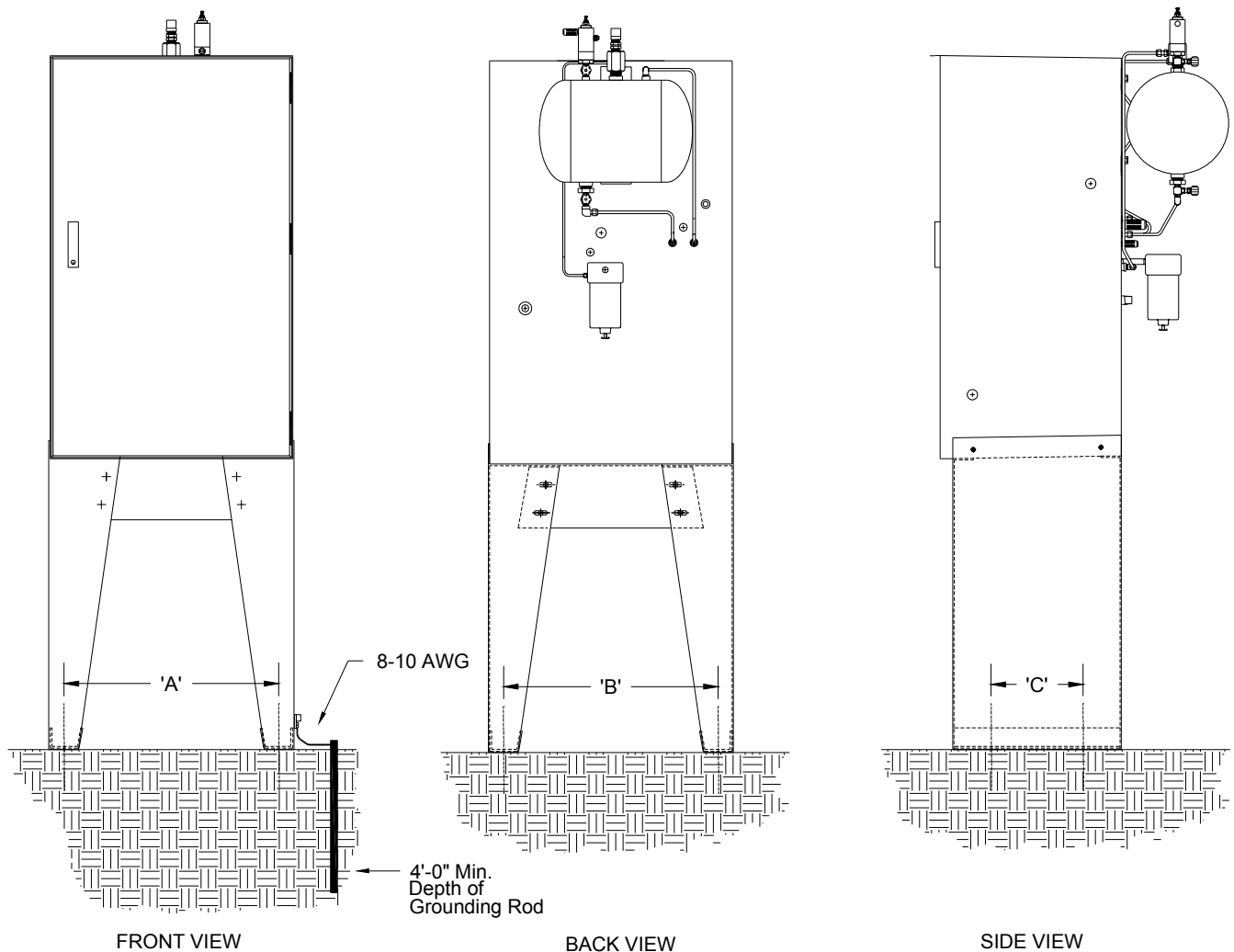

SECTION 2: SYSTEM INSTALLATION

Standard System Connections

Required field connections to place the 6300G into operation are as follows:

1. *Connect the solar panel cable to the system power supply, SPS-12, *figure 6*.

Note: *the solar panel should be mounted free of obstructing shade and should be facing south in the northern hemisphere or facing North in the southern hemisphere.*

- 1a. *If your system was ordered with the optional LPS120/240 power supply, AC power should be connected in accordance with explosion-proof code via a termination junction box (not shown) to be attached to the conduit provided at the upper left side on the system enclosure. The nominal power requirement for 120VAC will be 100 mA or for 240VAC will be 50mA. These power inputs must be fused with a maximum of 15A, *figure 7*. Minimum allowable operational voltage range for input is 85VAC to 250VAC.

2. Connect the flow signal device to the termination block located in the system control enclosure, *figure 8*, [refer to the Wiring Control Document on page 116 in Appendix D](#).

- 2a. If used, connect the optional Inhibit Input signal to the termination block located in the system control enclosure, *figure 8*, [refer to the Wiring Control Document on page 116 in Appendix D](#).

- 2b. If used, connect the RS-485 communication wiring as required to the termination block located in the system control enclosure, *figure 8*, [refer to the Wiring Control Document on page 116 in Appendix D](#).

* ATEX installations refer to Appendix E, page 117.



Figure 6



Figure 7

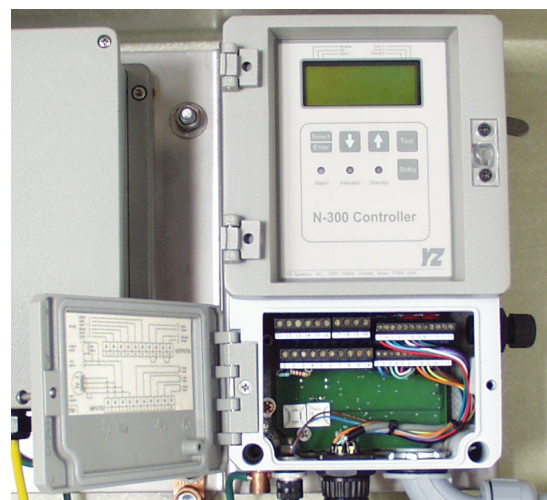

Figure 8

SECTION 2: SYSTEM INSTALLATION

CAUTION:

Excessive tubing lengths should be avoided. Installation of the NJEX Odorization system should be as close to the point of injection and Odorant Storage Tank as possible. Maximum tubing length should not exceed 15' (4.5 meters) with the tubing size maintained as indicated in this manual. If longer tubing lengths are required consult YZ Systems Technical Services at: 800.653.9435 or 1.281.362.6500.

3. Connect the odorant supply source to the odorant inlet manifold with the recommended 1/4" stainless steel tubing, *figure 9*. A tank isolation valve should be incorporated between the storage tank and this connection, *figure 9*.
4. Connect the regulated actuation gas source, of 75 psi (5.17 Bar) supplied by the NJEX system owner, to the NJEX gas filter inlet fitting using a dielectric union, *figure 9*.
 - For Pipeline pressures less than 200 psig a single cut regulator (Fisher 67 YZ P/N A3-0042 or similar) adjustable to provide 75 psig to the inlet gas filter on the NJEX enclosure should be acceptable.
 - P/L pressure above 200 psig need a dual cut regulation process:
 1. Install the primary regulator on the pipeline *Fisher 1301 YZ P/N A3-0274 or similar), and adjust it to provide 150 psi to the secondary regulator.
 2. Install the secondary regulator at the inlet gas filter on the back of the NJEX enclosure (Fisher 67 YZ P/N A3-0042 or similar), and adjust it to provide 75 psig to the NJEX System should be acceptable.
 3. 3/8" Stainless Steel tubing should be used between the two regulators.
 - Dual Pump enclosures, may require larger tubing between the regulators, and the secondary regulator may need to have a larger orifice (Fisher 64 or similar), if both pumps run simultaneously.

Note: *in applications where the actuation gas supply has a high water content and/or a low hydrocarbon dew point, additional actuation gas filtration or heating of the 6300G system may be necessary. Bottled nitrogen can also be used during cold operating conditions to avoid condensation in the actuation gas supply line. Also, an actuation gas source pressure of 75 psi (5.17 Bar) should be adequate in most installations.*

5. Connect the pipeline port of the odorant discharge manifold to the pipeline connection using dielectric union and check valve, *figure 9*.

6. If a heater option was specified with this odorizer, 120 / 240 VAC electricity *refer to the heater wiring diagram, page 106*, should be connected to the electrical inlet located on the lower side of the enclosure using 1/2" conduit and appropriate pack off. Power requirements for the heater are 1.6A for the 120VAC heater, and .833A for the 240VAC heater. Each heater is a thermostatically controlled 200Watt unit, *figure 10*. Dual unit enclosures may have dual heater elements . Values provided are per heater element.

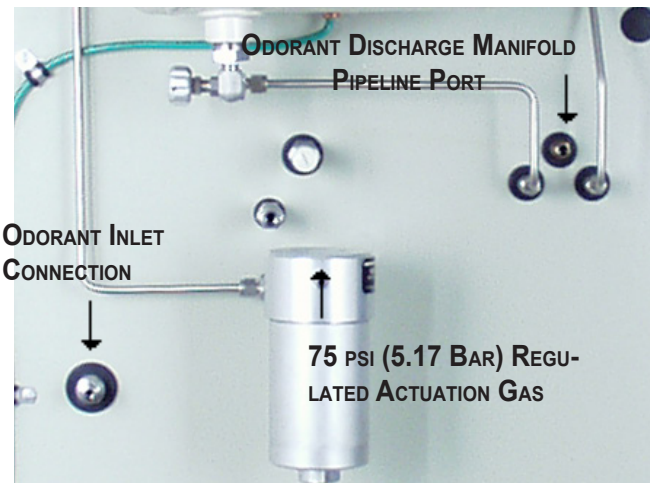

Figure 9



Figure 10

SECTION 2: SYSTEM INSTALLATION

Skid System Components

Introduction

The NJEX SkidMount Series of odorization systems is a total system approach to odorization. These systems are completely factory assembled, tested, and delivered requiring only three field connections to be fully operational. The NJEX SkidMount Systems offer all the advantages of our standard 6300G Systems plus the added benefit of an onboard odorant storage tank. The configuration allows for a total systems approach to odorization.

The SkidMount Systems come standard with an electronic level indicator factory connected to the N-300G controller. The controller has an alarm capability to indicate when the liquid level in the storage tank has fallen below a predetermined level set by the operator.

The Systems are available with 20, 60, 120, 250, 500 and 1000 gallon tank sizes. (Larger sizes are available up to 10,000 gallons by custom order.)

Skid system primary components of the NJEX-6300G include the following:

- **Skid Mounted Tank** a pre-assembled, and tested Structural steel skid with odorant tank, valve package, skid piping, and system enclosure.
- **NJEX System Enclosure**, *figure 11*, houses and protects the; 6000 pump, VM-1000 Verometer, odorant fill valve, solenoid valve/pneumatic relay manifold, odorant discharge manifold, N-300 system controller enclosure, *power supply enclosure, and bulk odorant filter.
- ***SPS-12 – Solar Panel Assembly**, *figure 11*, is standard equipment for the 6300G and includes a mounting bracket and a connection cable. Optional LPS-120/240 may be used in lieu of the solar panel.
- **System Control Enclosure** for the N-300G controller.
- ***Power Supply Enclosure** for the battery and charging system.



Figure 11

* ATEX installations refer to Appendix E, page 117.

SECTION 2: SYSTEM INSTALLATION

- **Bulk Odorant Filter**, *figure 12*, provides primary odorant filtration between the storage tank and the NJEX-6300G. The bulk odorant filter is pre-installed inside the system enclosure attachment to the odorant source is via a bulk filter manifold equipped with 1/4" FNPT connection located on the back of the system enclosure.
- **Mechanical Interconnect Cable**, *figure 12*, provides the connection between the system control enclosure and the electrical components located in the mechanical section.
- **Expansion Tank**, *figure 13*, provides a closed loop system for pressure fluctuations within the Verometer during the odorant fill and injection cycle.
- **NJEX Gas Filter**, *figure 13*, installed between the actuation gas regulator and the actuation gas manifolds provides a 25 micron coalescent filtration to insure a clean pneumatic supply.
- **Actuation Gas Regulator**, *figure 12*, provides additional regulation of supply gas to actuate the pump.
- **Service Tray**, (*Not Illustrated*), should be installed in the bottom of the system enclosure, to capture any drops that may occur during servicing of the odorizer.

Actuation Gas Regulator



Figure 12

Bulk Odorant Filter



Figure 13

SECTION 2: SYSTEM INSTALLATION

Figure 14

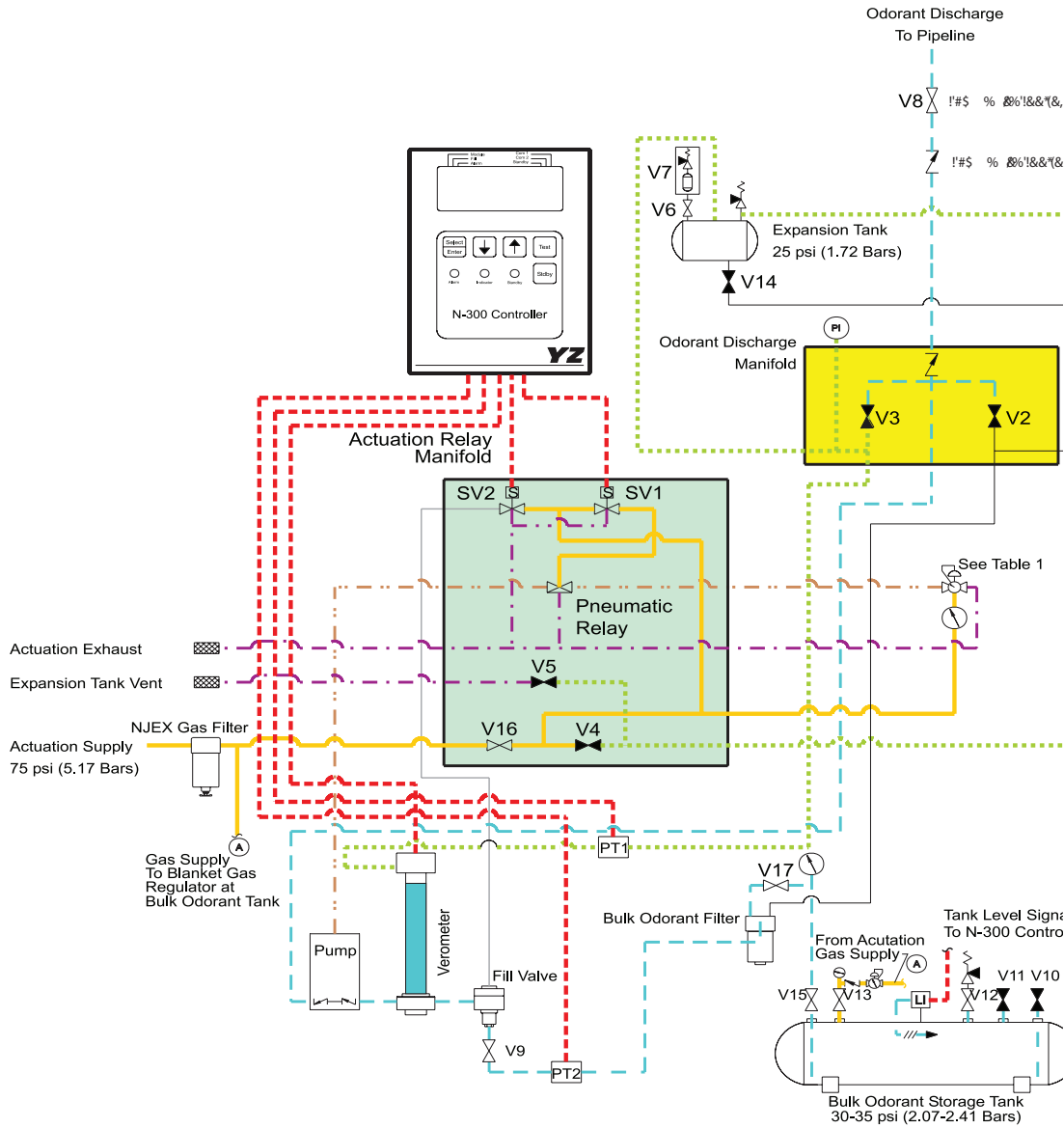

6300	
Pipeline Pressure	Actuation Pressure
100-200 psi (6.89-13.8 Bar)	30 psi (2.07 Bar)
200-500 psi (13.89-34.5 Bar)	40 psi (2.76 Bar)
500-900 psi (34.5-62.1 Bar)	50 psi (3.45 Bar)
900-1400 psi (62.1-96.5 Bar)	60 psi (4.14 Bar)

IMPORTANT: Read And Follow Steps 1-4 BEFORE Proceeding

- Place the controller in the "standby" mode.
- Close all valves marked "X".
- Open all valves marked "O".
- Place controller in the proper mode of operation as needed.

	V2	V3	V4	V5	V6	V7	V8	V9	V10	V11	V12	V13	V14	V15	V16
Normal Operation	X	X	X	X	O	O	*	X	O	O	O	X	O	X	O
System Purge	O	X	X	X	X	*	X	X	O	O	O	X	O	X	O
System Vent	O	O	X	O	X	*	X	X	O	O	O	X	O	X	O
Leak Test	O	O	X	X	X	*	X	X	X	O	O	X	O	X	O
Prime Pump	X	O	X	X	O	X	*	X	X	O	O	O	X	O	O

* - Adjust as needed

LEGEND

- Normally Closed Valve

Normally Open Valve

Pneumatic Relay

Check Valve

Float Valve

Pressure Gauge

Electronic Level Transmitter

Solenoid Valve

Pressure Regulator w/Gauge

Pressure Relief Valve

Pressure Transmitter
- Liquid Odorant - Normal Operation

Purge/Drain Line

Expansion Line

Intrinsically Safe Electrical Line

Exhaust/Vent Line

Actuation Line 75 psi (520 Kpa)

Fill Valve Actuation Line

Pump Actuation Line
- V2 Purge Valve (Red Knob)

V3 Prime Valve (Blue Knob)

V4 Expansion Tank Pressure Supply Valve (Gold Knob)

V5 Expansion Tank Vent Valve (Green Knob)

V6 Expansion Tank Overflow Preventor Isolation Valve

V7 Expansion Tank Overflow Preventor

V8 Isolation Valve

V9 Fill Rate Control Valve

V10 Odorant Storage Tank Fill Valve

V11 Odorant Storage Tank Vapor Return Valve

V12 Odorant Storage Tank Relief Valve Isolation Valve

V13 Odorant Storage Tank Expansion Tank Isolation Valve

V14 Expansion Tank Drain Valve

V15 Odorant Storage Tank Supply Isolation Valve

V16 Gas Supply Isolation Valve (Black Knob)

V17 System Odorant Supply Isolation Valve

SV1 Pump Actuation Pilot Solenoid Valve

SV2 Fill Valve Solenoid Valve

PT1 Expansion Tank Pressure Transmitter

PT2 Odorant Inlet Pressure Transmitter

SECTION 2: SYSTEM INSTALLATION

Skid System Mounting

Figure 15

1. Bolt down the system to a concrete slab using the 3/4" mounting holes provided in the skid. The size of the concrete slab is recommended to exceed the NJEX System skid length and width dimensions by 12". Recommended mounting bolt/stud sizes are either 11/16" or 5/8" for securing the skid to the slab.
2. Connect a ground wire from one of the grounding lugs located on the skid to a properly installed ground rod located adjacent to the skid.

RAIL SKID SYSTEMS						
TANK <i>gallons</i>	CABINET	BL <i>inches</i>	BW <i>inches</i>	L <i>inches</i>	W <i>inches</i>	WEIGHT <i>pounds</i>
20	Either	47	47	49	49	450
60	Either	52	52	54	54	550
120	Single	96	26	98	28	750
	Double	96	47	98	49	800
250	Either	122	47	124	49	1150
500	Either	147	47	149	49	1600
1000	Either	220	47	222	49	2750
2000	Either	318	48 1/2	322	52 1/2	6600

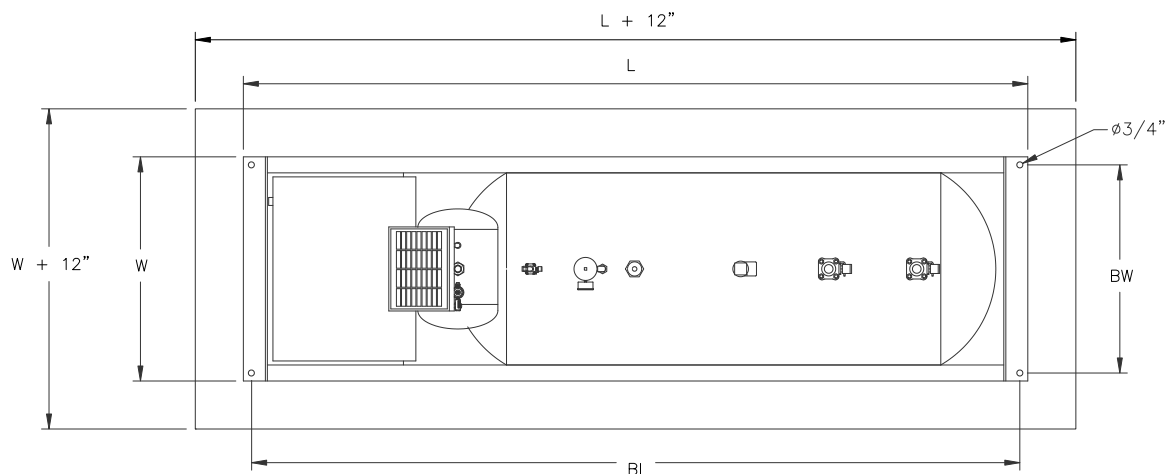

SECTION 2: SYSTEM INSTALLATION

CONTAINMENT SKID SYSTEMS							
TANK gallons	CABINET	BL inches	BW inches	O inches	L inches	W inches	WEIGHT pounds
20	Single	50	32	8	66	36	800
	Double	31	58	7	45	62	850
60	Single	56	32	8	72	36	950
	Double	36	58	7	50	62	1000
120	Single	82	32	8	98	36	1200
	Double	82	54	8	98	58	1350
250	Either	108	58	8	124	62	1850
500	Either	116	58	8	154	62	2600
1000	Either	192	64	8	240	68	4250
2000	Either	252	69	14	318	73	7850

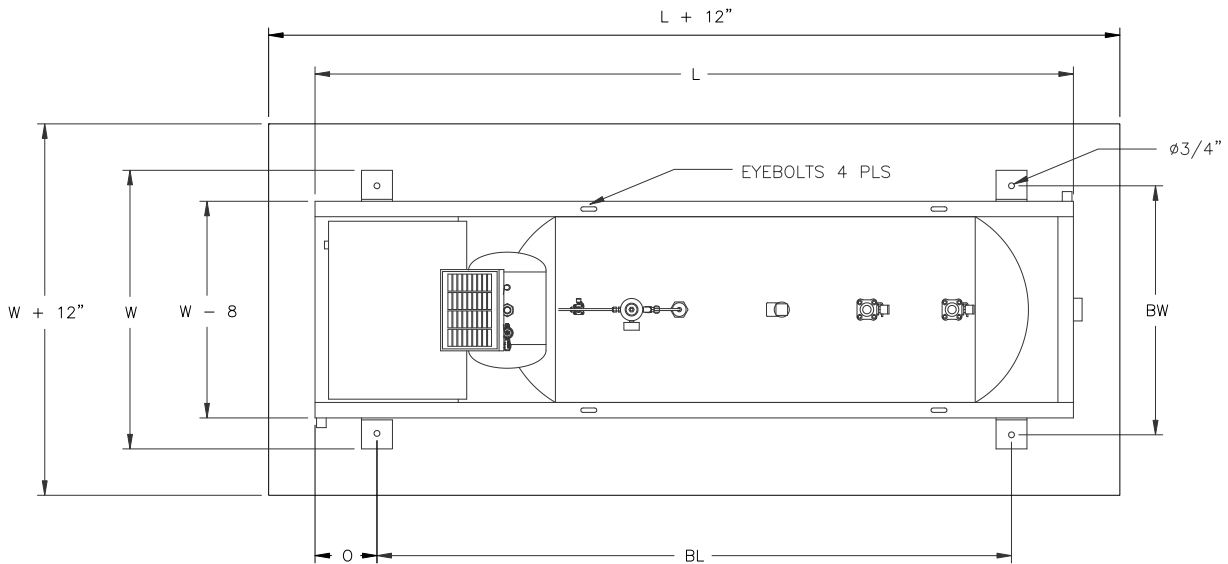

SECTION 2: SYSTEM INSTALLATION

Skid System Connections

Required field connections to place the 6300G into operation are as follows:

1. *Connect the solar panel cable to the system power supply, SPS-12, *figure 16*.

Note: the solar panel should be mounted free of obstructing shade and should be facing south in the northern hemisphere or facing north in the southern hemisphere.

- 1a. *If your system was ordered with the optional LPS-120/240 power supply, AC power should be connected in accordance with explosion-proof code via a termination junction box to be attached to the conduit provided at the upper left side on the system enclosure. The power requirement for 120VAC will be 100 mA. The power requirement for 240VAC will be 50 mA. These power inputs must be fused with a maximum of 15A, *figure 17*, refer to the [Wiring Control Document on page 116 in Appendix D](#).
2. Connect the flow signal device to the termination board located in the system control enclosure via the conduit hubs to the N-300G, *figure 18*, refer to the [Wiring Control Document on page 116 in Appendix D](#).
- 2a. If used, connect the optional Inhibit Input signal to the termination board located in the system control enclosure, *figure 18*, refer to the [Wiring Control Document on page 116 in Appendix D](#).
- 2b. If used, connect the RS-485 communication wiring as required to the termination board located in the system control enclosure, *figure 18*, refer to the [Wiring Control Document on page 116 in Appendix D](#).

* ATEX installations refer to Appendix E, page 117.



Figure 16



Figure 17



Figure 18

SECTION 2: SYSTEM INSTALLATION

CAUTION:

Excessive tubing lengths should be avoided. Installation of the NJEX Odorization system should be as close to the point of injection and Odorant Storage Tank as possible. Maximum tubing length should not exceed 15' (4.5 meters) with the tubing size maintained as indicated in this manual. If longer tubing lengths are required consult YZ Systems Technical Service Department at; 800.653.9435 or 1.281.362.6500.

3. Connect the pipeline port, the center 1/4" tubing connector of the odorant discharge manifold to the pipeline connection using a dielectric union, figure 19.
4. Connect the regulated actuation gas source, of 75 psi (5.17 Bar) supplied by the NJEX system owner, to the NJEX gas filter inlet fitting using a dielectric union, figure 19.
 - For pipeline pressures less than 200 psig a single cut regulator (Fisher 67 YZ P/N #A3-0042 or similar) adjustable to provide 75 psig to the inlet gas filter on the NJEX enclosure should be acceptable.
 - P/L pressure above 200 psig need a dual cut regulation process:
 1. Install the primary regulator on the pipeline (Fisher 1301 YZ P/N A3-0274 or similar), and adjust it to provide 150 Psi to the secondary regulator.
 2. Install the secondary regulator at the inlet gas filter on the back of the NJEX enclosure (Fisher 67 YZ P/N A3-0042 or similar), and adjust it to provide 75 psig to the NJEX system should be acceptable.
 3. 3/8" Stainless Steel tubing should be used between the two regulators.

Note: in applications where the actuation gas supply has a high water content and/or a low hydrocarbon dew point, additional actuation gas filtration or heating of the 6300G system may be necessary. Bottled nitrogen can also be used during cold operating conditions to avoid condensation in the actuation gas supply line. Also, an actuation gas source pressure of 75 psi (5.17 Bar) should be adequate in most installations.

5. Connect the pipeline port of the odorant discharge manifold to the pipeline connection using a dielectric union and check valve, figure 19.
6. If a heater option was specified with this odorizer, 120/240 VAC electricity refer to the heater wiring

diagram, page 106 should be connected to the electrical inlet located on the lower side of the enclosure using 1/2" conduit and appropriate pack off. Power requirements for the heater are 1.67A for the 120VAC heater, and .833A for the 240VAC heater. Each heater is a thermostatically controlled 200Watt unit, figure 20. Dual unit enclosures may have dual heater elements. Values provided are per heater element.

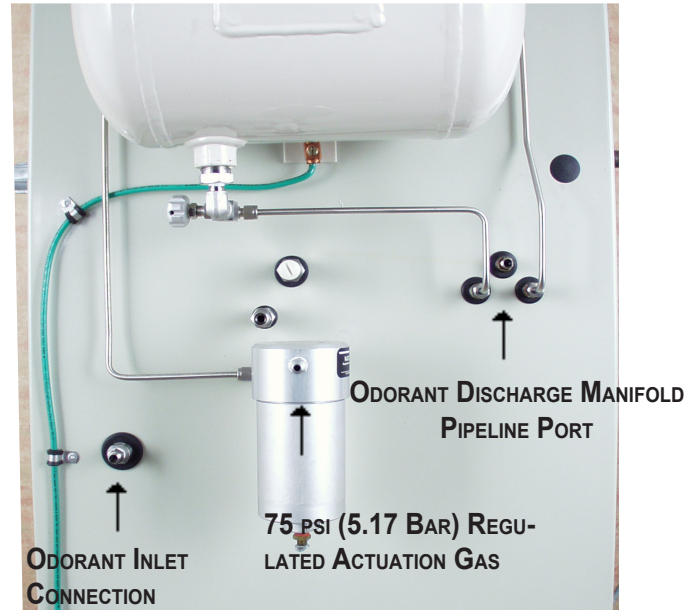

Figure 19



Figure 20

SECTION 3: FILLING THE BULK ODORANT TANK

Filling the Tank for the First Time

CAUTION:

Odorant has a very strong odor, which if allowed to escape to the atmosphere, may cause problems in the local community. Take necessary precautions when filling an odorant storage tank to assure that the local community is not disrupted during the filling process. Verify that the entire system has no pressure in it before beginning. Additionally, all personnel should wear protective clothing, and use equipment as recommended by the chemical manufacturer during this time. If you are uncertain about any aspect of the odorant itself, you should contact the manufacturer of your chemical prior to proceeding.

1. Verify correct position of valves before beginning, figure 21.

Open: **V12**, and **V13***

Closed: **V10**, **V11**, and **V15**

**Note Gas Supply to V13 should NOT be turned on during this procedure.*

2. Attach inert or natural gas supply to **V10**.
3. To purge the tank open valve **V10** to introduce

inert or natural gas to the tank to begin displacing any ambient air from the empty tank. Continue until pressure on the gage located directly above **V13** is observed, then partially open **V11** to allow ambient air from the tank to begin flowing out. Allow this process to continue until all ambient air from the tank is purged, and only inert gas or natural gas is emitting from this valve, then close **V11** and **V10**. The time required to accomplish this task will vary with the tank size.

4. Vent purge gas by opening **V11** partially until tank pressure just reaches zero, and then close **V11**.
5. Attach odorant supply to **V10**, open **V10**, and begin transferring odorant to the bulk tank.
6. Connect a line from **V11** to a flare or vapor recovery device, and open **V11**.

CAUTION:

Fill tank to a maximum level of 80% of the tank capacity.

7. Close **V10** and **V11**, and remove odorant transfer equipment, and line to flare or vapor recovery device.
8. Continue through the remaining procedures in this manual.

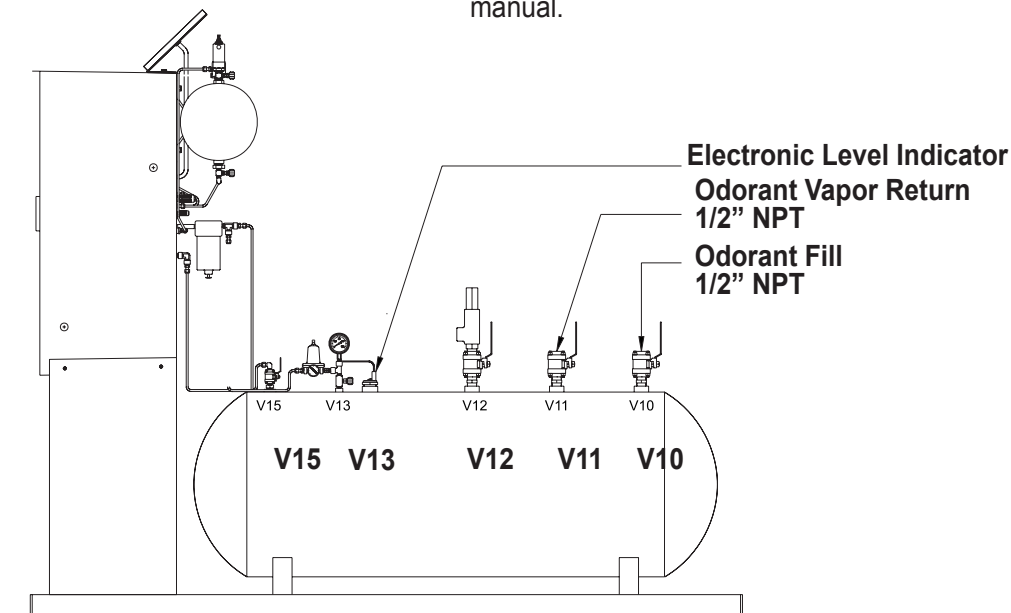

Figure 21

SECTION 3: FILLING THE BULK ODORANT TANK

Refilling the Bulk Odorant Tank

CAUTION:

Odorant has a very strong odor, which if allowed to escape to the atmosphere, may cause problems in the local community. Take necessary precautions when filling an odorant storage tank to assure that the local community is not disrupted during the filling process. Verify that the entire system has no pressure in it before beginning. Additionally all personnel should wear protective clothing, and use equipment as recommended by the chemical manufacturer during this time. If you are uncertain about any aspect of the odorant itself, you should contact the manufacturer of your chemical prior to proceeding.

1. Place the N-300G controller in the Standby Mode by pressing the **Standby** key.
2. Verify correct position of valves before beginning, figure 22.

Open: **V12**

Closed: **V10, V11, V13, V15**

3. Connect a line from **V11** to a flare or vapor recovery device, and open **V11**.
4. Attach odorant supply to **V10**, open **V10**, and begin transferring odorant to the bulk tank.

CAUTION:

Fill tank to a maximum level of 80% of the tank capacity.

5. Close **V10** and **V11**, and remove odorant transfer equipment, and line to flare or vapor recovery device.
6. Open **V13** and **V15**.
7. Place the N-300G controller in the Run Mode by pressing the **Standby** key.

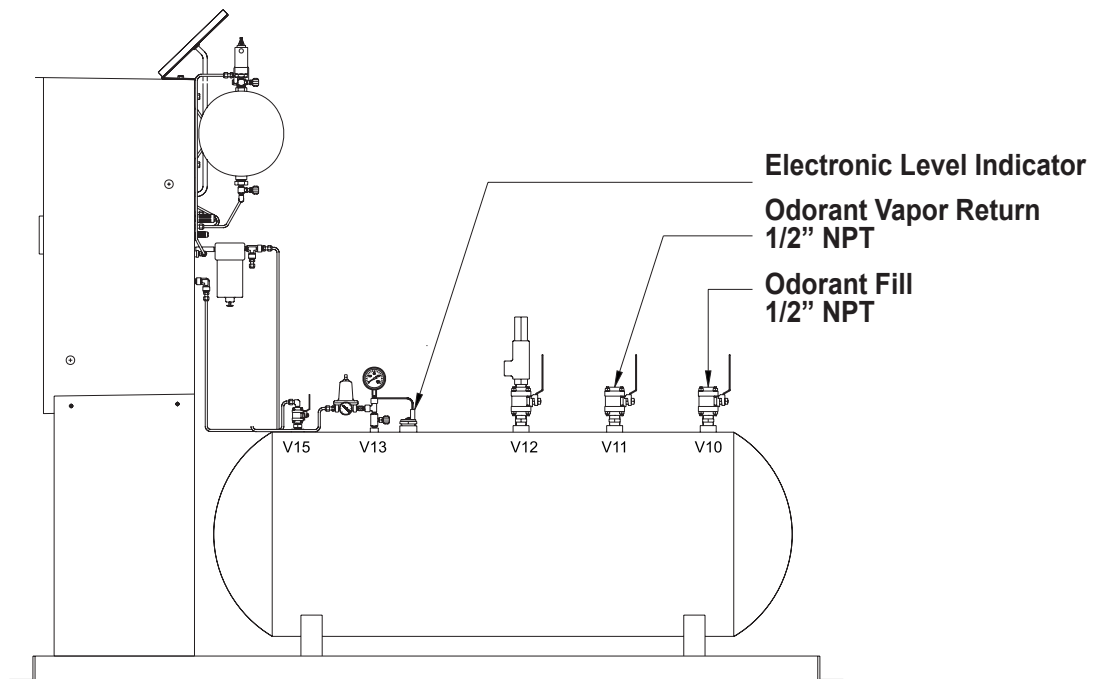

Figure 22

SECTION 4: SYSTEM CONTROL & ELECTRONICS

Overview

The 6300G control/electronics system is composed of the system control enclosure and the *SPS-12 solar charged power supply, or a *LPS 120/240 charger supply, *figure 23*. Individual components of the system are shown below and are described in the following pages. A flow chart of the N-300G controller menu system is illustrated on the N-300G Display Diagram located *on page 115 in Appendix D: Documents*.

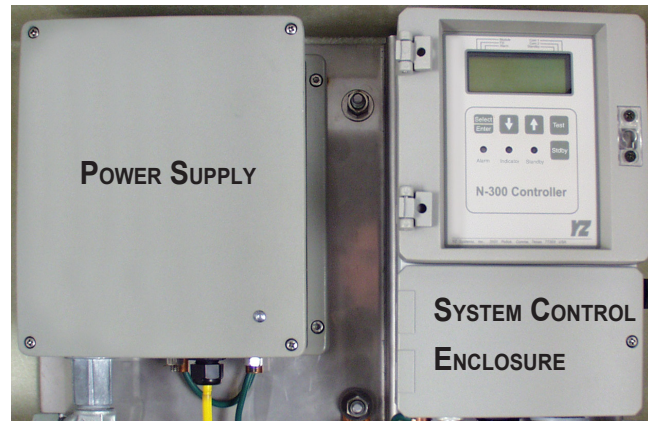

Figure 23

To Use The Key Pad

The three main keys have multiple function capabilities. Each key is labeled with it's primary function used in moving through the menu, they are as follows:

Select / Enter  

The Select / Enter Key Up Arrow Key & Down Arrow Key

These keys also have alternative functions. These alternative functions will be reflected in the commands, preceded by an asterisk "*", that appear in a corresponding position to the key on the N-300G display. For example in *figure 24*:

- To choose ***Start**, you would press the **Select / Enter** key.

- To choose ***Dsp**, you would select the  Key.

- To choose ***Set**, you would select the  Key.



Figure 24

* ATEX installations refer to Appendix E, page 117.

SECTION 4: SYSTEM CONTROL & ELECTRONICS

To Power Up The System

Open the N-300G Controller Enclosure, *figure 25*, and find the toggle switch **S1** located just below center on the right side of the Printed Circuit Board – PCB. Turn on the main power switch by toggling the switch to up position.

Once powered-up, the menu sequence, *figure 26*, will appear. Follow the menu instructions on the LCD screen as they are presented.

Check to ensure the serial number and model type shown match the serial number and model type on the left side of the electronics enclosure and on the inside of mechanical enclosure door. Also check to ensure the verometer calibration number matches the verometer tag number located at the top of the verometer assembly, *figures 27, 28 & 29*.

Next you may have the option of accepting a set of Pre-Configured operating parameters, that have been programmed into the Sentry Module, *figure 30*. This option will only come up if it has been set up in Sentry and not previously uploaded.

Record the version x.xx number, *figure 31*, in the **For the Record Form** located on Page 113 in Appendix C: *Forms* of this manual for future reference.

IMPORTANT:

If the serial number, model type, or the verometer tag number do not match the corresponding numbers in the N-300G controller consult the factory before proceeding further.

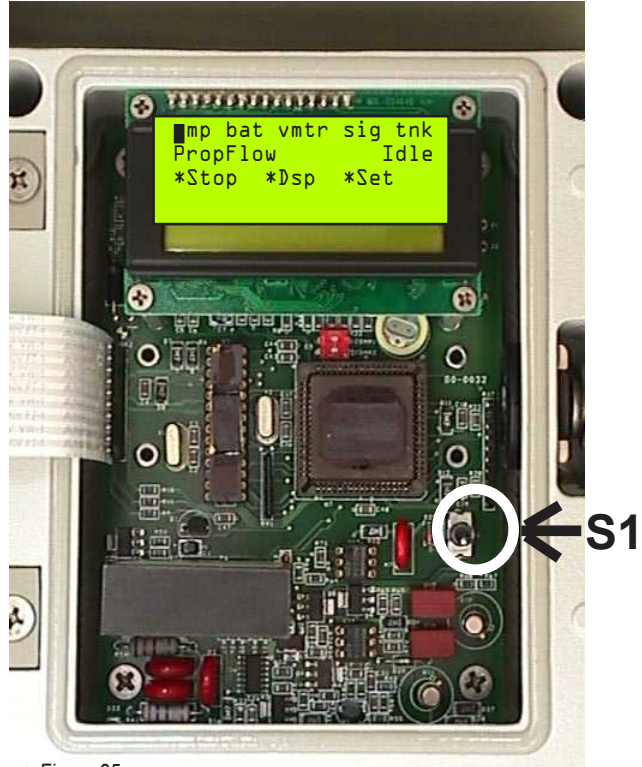

Figure 25

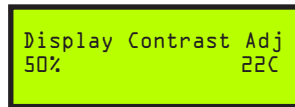

Figure 26

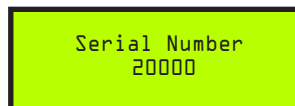

Figure 27



Figure 28

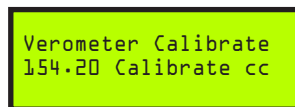

Figure 29

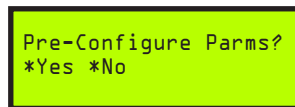

Figure 30

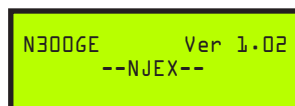
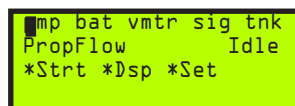

Figure 31



SECTION 4: SYSTEM CONTROL & ELECTRONICS

Test & Standby Keys

The **Test key**, *figure 32*, is located in the upper right quadrant of the N-300G touch pad and is used to manually stroke the pump. Simply press the test key touch pad to stroke the pump. Each time the test key is pushed, the pump should actuate and the N-300G display will show **Strk** just above the **Test** key touch pad. The strokes signaled counter will advance for each stroke of the pump. The odorant injected counter will also advance when the pump displaces a sufficient volume of odorant to register .001 lb (.001 kg) of odorant.

The **Standby key**, *figure 32*, allows the operator to locally inhibit the operation of the N-300G controller. This creates a standby mode for the 6300G system. In the event of a no flow condition in the pipeline, the operator can switch the 6300G to a standby mode for extended periods of time, or to temporarily suspend operation of the system for maintenance. When flow is initiated once more, or the maintenance has been completed, the 6300G can be switched from standby to operation without the need to restart the N-300G controller.

Remote Inhibit Mode, can also be applied to interrupt odorization in a manner similar to the standby mode however, it is initiated by applying a dry contact, or open collector signal, to the termination board TB1, terminals #9 and #10, *figure 33*, [refer to the Wiring Control Document on page 116 in Appendix D: Documents](#). The **Remote Inhibit Mode's** function is identical to the **Standby Mode**. Activation will be indicated on the N-300G display and the Sentry4 event file differently. **Rmt Inhb** will appear on the N-300 main screen display where the count down time normally appears, *figure 33*.



Figure 32



Figure 33

SECTION 4: SYSTEM CONTROL & ELECTRONICS

*Battery & Solar Panel Assembly

The 6300G standard system is solar powered using a five watt solar panel, and a *Solar Power Supply – SPS-12 which includes a regulator and *12 volt DC battery, *figures 34 & 35*. The 6300G will operate approximately 30 days without additional power generated by the solar panel. The battery is continuously monitored and an alarm signal is sent if the voltage falls below 11.0 volts. During normal operation the LED, located on the front of the SPS-12 will illuminate.

***If AC power is available**, the solar panel can be replaced with an optional 120/240 AC/DC Line Power Supply – LPS, *figure 36*, intrinsically safe barrier, and an enclosure for Class I, Division 1, Group C, D locations. The battery is included in the system to provide system operation and back up power for up to 30 days, in the event of an AC power failure.

SOLAR PANEL

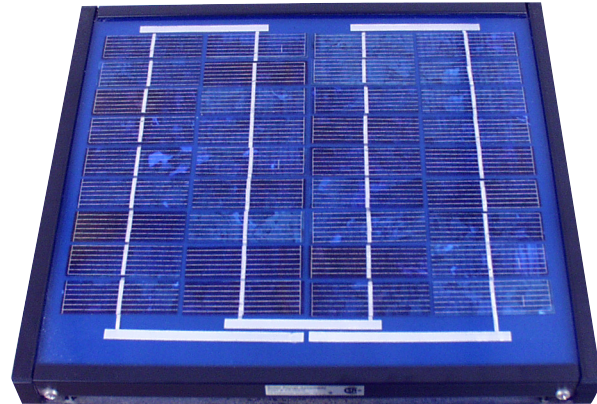

Figure 34

LPS AND BATTERY W/COVER REMOVED

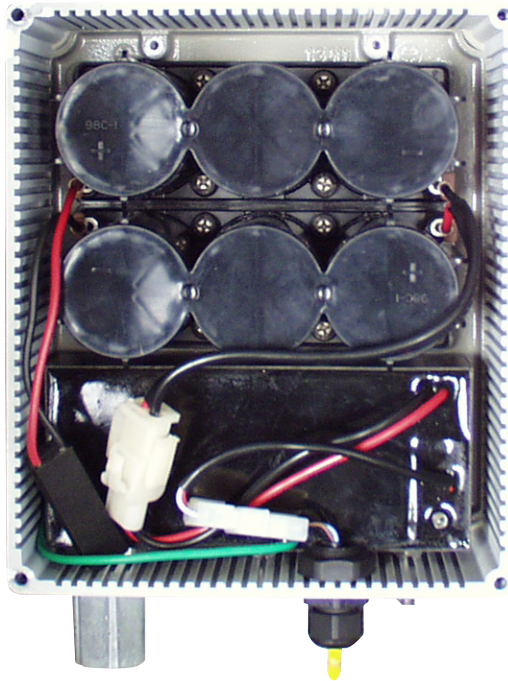

Figure 36

SPS AND BATTERY W/COVER REMOVED

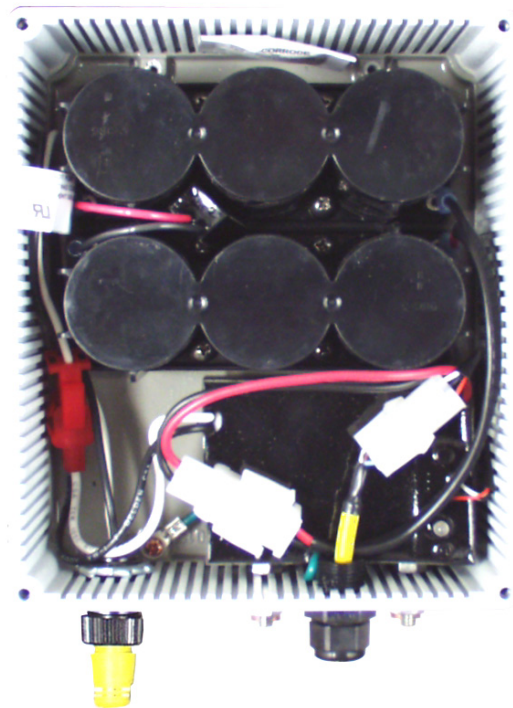

Figure 35

SECTION 4: SYSTEM CONTROL & ELECTRONICS

Communications Interface

There are three methods of communicating information out of the N-300 controller.

- **Method 1**, utilizes Communications Modbus protocol. Specifications to permit configuration can be found on [page 107, Appendix B: N300 Modbus Specifications](#).
- **Method 2**, utilizes the Sentry Software installed on a computer. In this mode the computer can communicate with the NJEX system & obtain information, or the NJEX system may be configured to notify the computer and provide it with information.
- Connections for Method 1 or 2 are via an RS-485 two wire connection. In a safe, nonhazardous area this may be connected to a RS-232 converter for interface with a SCADA system if required.
- **Method 3**, utilizes two output relays. One relay is for **Alarm Output**, and provides single output communication to indicate some type of some alarm has occurred with the odorizer. The second output relay is for a **Scaled Pulse** relative to a programmed volume of odorant injected by the system, [refer to the Wiring Control Document on page 116 in Appendix D: Documents](#).

Comm-Link Configuration

The 6300G system may be communicated to through on one or two available RS485 communication ports.

The N-300 Modbus specification can be found on [page 107, Appendix B: N300 Modbus Specifications](#).

SECTION 5: PROGRAMMING FOR PROPORTIONAL-TO-FLOW OPERATION

Setting Operator Input Parameters

- Choose **Set** in the main menu, *figure 37*.
- Choose **Par** – *parameters* in the set selection menu, *figure 38*.
- Choose **Flow** in the set parameters menu, *figure 39*.
- Choose **Set** in the proportional-to-flow menu, *figure 40*.

Odorant injection rate in lbs/MMCF(mg/m³) of gas

To set the injection rate, *figure 41*, press and release the **Select** key. The value entry will begin to flash when chosen. Use the **Up Arrow** key to increase the value and the **Down Arrow** key to decrease the value. When a new value has been chosen, press the **Enter** key to store the new value into memory. The entered value will stop flashing when it has been loaded into memory. Press the **Down Arrow** key to advance to the next parameter.

Pump displacement in cc/stroke

To set the pump displacement, *figure 42*, press and release the **Select** key. The value entry will begin to flash when chosen. Use the **Up Arrow** key to increase the value and the **Down Arrow** key to decrease the value. When a new value has been chosen, press the **Enter** key to store the new value into memory. The entered value will stop flashing when it has been loaded into memory. Press the **Down Arrow** key to advance to the next parameter.

Odorant density in lbs/gallon (g/cc) @ 60° F

To set the odorant density, *figure 43*, press and release the **Select** key. The value entry will begin to flash when chosen. Use the **Up Arrow** key to increase the value and the **Down Arrow** key to decrease the value. When a new value has been chosen, press the **Enter** key to store the new value into memory. The entered value will stop flashing when it has been loaded into memory. Press the **Down Arrow** key to advance to the next parameter.

*designates optional key function

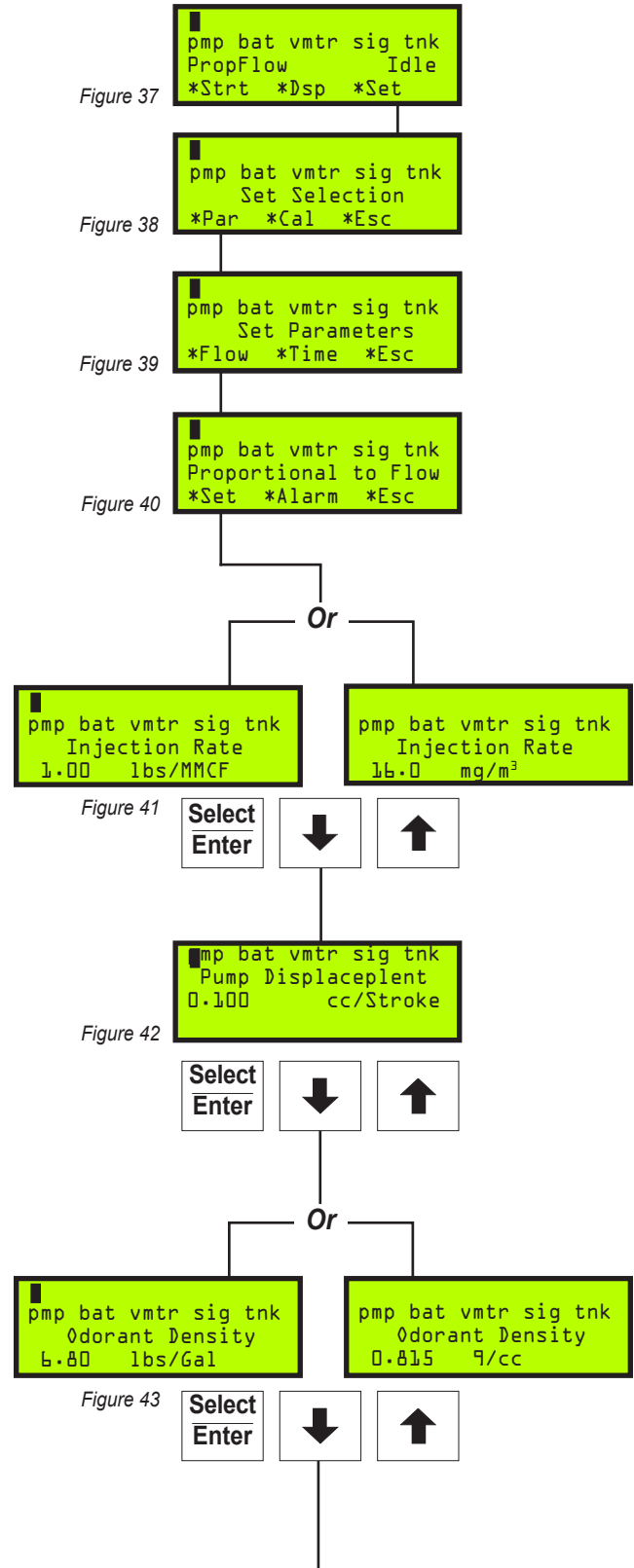

SECTION 5: PROGRAMMING FOR PROPORTIONAL-TO-FLOW OPERATION

Setting Operator Input Parameters, *Continued*

Max gas flow in MMCF/Hour (m3/sec)

Max gas flow is the maximum flow rate at which the flow input reaches full scale span.

To set the max gas flow, *figure 44*, press and release the **Select** key. The value entry will begin to flash when selected. Use the **Up Arrow** key to increase the value and the **Down Arrow** key to decrease the value. When a new value has been chosen, press the **Enter** key to store the new value into memory. The entered value will stop flashing when it has been loaded into the memory. Press the **Down Arrow** key to advance to the next parameter.

Low Flow Shut Off

The **low flow shut off setting**, allows a preset point in a percentage of max gas flow desired to the N-300G to stop injecting odorant. This allows the controller to sense low flow conditions where the operation is not desired. This setting will override the max time /stroke setting parameter. When flow again increases above the preset point the N-300G resumes operation.

To set the low flow shut off, *figure 45*, press and release the **Select** key. The value entry will begin to flash when selected. Use the **Up Arrow** key to increase the value and the **Down Arrow** key to decrease the value. When a new value has been chosen, press the **Enter** key to store the new value into memory. The entered value will stop flashing when it has been loaded into the memory. Press the **Down Arrow** key to advance to the next parameter.

Flow (no signal)

The **flow (no signal) input setting**, is the predetermined percentage of max gas flow that the operator would like the controller to default to in the event that the actual flow input signal is lost.

Note: the **Flow (no signal) input functions** will only be active with analog input signals 1-5 VDC and 4-20 mA.

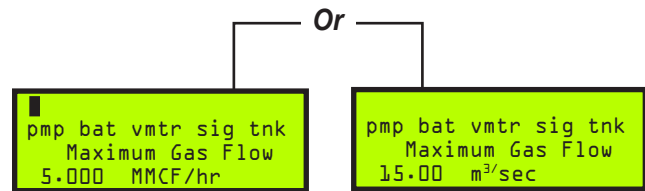

Figure 44

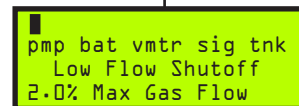

Figure 45

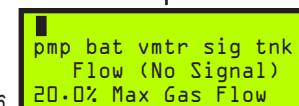

Figure 46



SECTION 5: PROGRAMMING FOR PROPORTIONAL-TO-FLOW OPERATION

To set the flow (no signal) input, figure 46a, press and release the **Select** key. The value entry will begin to flash when selected. Use the **Up Arrow** key to increase the value and the **Down Arrow** key to decrease the value. When a new value has been chosen, press the **Enter** key to store the new value into memory. The entered value will stop flashing when it has been loaded into the memory. Press the **Down Arrow** key to advance to the next parameter.

Maximum Time/Stroke

The maximum time/stroke setting, is the maximum time between strokes, when a stroke time is actually calculated, desired regardless of the time calculated by the controller. *This feature is not active under low-flow or no-flow conditions.*

To set the maximum time/stroke, figure 47, press and release the **Select** key. The value entry will begin to flash when selected. Use the **Up Arrow** key to increase the value and the **Down Arrow** key to decrease the value. When a new value has been chosen, press the **Enter** key to store the new value into memory. The entered value will stop flashing when it has been loaded into memory. Press the **Down Arrow** key to advance to the next parameter.

The Odorant Output Setting

The odorant output setting, controls the scaling of the odorant output relay in lbs/pulse (*kg/pulse*). This indicates how much odorant has been injected with each pulse of the output relay located **TB1**, terminals **#19** and **#20**, refer to the [Wiring Control Document on page 116 in Appendix D: Documents](#).

To set the odorant output, figure 48, press and release the **Select** key. The value entry will begin to flash when selected. Use the **Up Arrow** key to increase the value and the **Down Arrow** key to decrease the value. When a new value has been chosen, press the **Enter** key to store the new value into memory. The entered value will stop flashing when it has been loaded into memory. Press the **Down Arrow** key to advance to the next parameter.

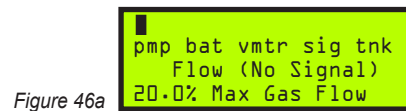

Figure 46a

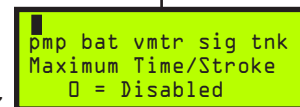

Figure 47



Or

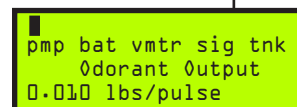
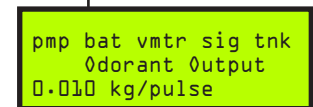

Figure 48



SECTION 5: PROGRAMMING FOR PROPORTIONAL-TO-FLOW OPERATION

Setting Operator Input Parameters, *Continued*

Odorant Tank

Optional Set-up: Functional ONLY if a complete YZ Skid Mounted Tank System is supplied.

1. **Disabled:** no level monitoring, 0% = disabled, both Low & High settings must be disabled.
2. **Enabled:** 0-100% level monitoring with two alarms that may be triggered from this level reading, a High Tank Level Tank Alarm, and a Low Tank Level Tank Alarm.

To set the alarm level points, *figure 49*, press and release the **Select** key. The Low Level value will begin to flash when chosen. Use the **Up Arrow** key to increase the value and the **Down Arrow** key to decrease the value. This alarm should typically be set between 5% and 25%. When a new value has been chosen, press the **Enter** key to store the new Low Level Alarm setting into memory. The entered value will stop flashing when it has been loaded into memory, the High Level value will begin to flash. Use the **Up Arrow** key to increase the value and the **Down Arrow** key to decrease the desired value. This alarm should typically be set at less than 80%. When a new value has been chosen, press the **Enter** key to store the new High Level Alarm setting into memory. Press the **Down Arrow** key to advance to the next menu.

Expansion Tank Pressure Monitoring

Typical expansion tank pressure is approximately 25 psi (1.72 Bar). There are two alarms that can be triggered, a High Pressure Expansion Tank Alarm, and a Low Pressure Expansion Tank Alarm, *figure 50*.

1. **Disabled:** no expansion tank pressure monitoring, 0% = disabled, both Low & High settings must be disabled. Normal operation should have this function enabled.
2. **Enabled:** Low Level should typically be set @ 23 psi (1.58 Bar), but is adjustable from 0 psi (0 Bar) up to the high level set point. High Level should typically be set @ 27 psi (1.86 Bar), but is adjustable from 0 psi (0 Bar) up to 99 psi (6.82 Bar).

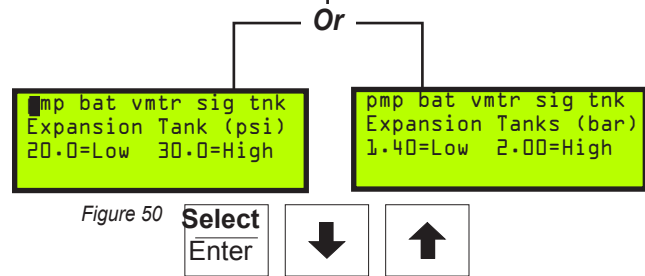
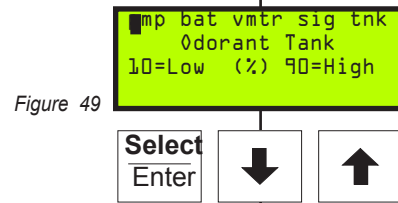

SECTION 5: PROGRAMMING FOR PROPORTIONAL-TO-FLOW OPERATION

To set the alarm level points, *figure 51*, press and release the **Select** key. The Low Pressure value will begin to flash when chosen. Use the **Up Arrow** key to increase the value and the **Down Arrow** key to decrease the value. When a new value has been chosen, press the **Enter** key to store the new Low Pressure setting into memory. The entered value will stop flashing when it has been loaded into memory. Next the High Pressure value will begin to flash. Use the **Up Arrow** key to increase the value and the **Down Arrow** key to decrease the value. When a new value has been chosen, press the **Enter** key to store the new High Pressure setting into memory. Press the **Down Arrow** key to advance to the next menu.

Odorant Inlet Pressure Monitoring

For the fill valve to function correctly a pressure differential between the Bulk Odorant Storage Tank and the Expansion Tank, must be maintained. This differential should never be less than 5 psi (.35 Bar) and typically not more than 10 psi (.69 Bar). There are two alarms that may be triggered from the Odorant Inlet Pressure reading, a High Odorant Inlet Alarm, and a Low Odorant Inlet Alarm.

To set the alarm level points, *figure 52*, press and release the **Select** key. The Odor Inlet Low value will begin to flash when chosen. Nominal low pressure in the Odorant Storage Tank is 30 psi (2.07 Bar). Use the **Up Arrow** key to increase the value and the **Down Arrow** key to decrease the value. When a new value has been chosen, press the **Enter** key to store the new Odor Inlet Low setting into memory. The entered value will stop flashing when it has been loaded into memory. Next the Odor Inlet High value will begin to flash. Nominal high pressure in the Odorant Storage Tank is 35 psi (2.41 Bar). Use the **Up Arrow** key to increase the value and the **Down Arrow** key to decrease the value. When a new value has been chosen, press the **Enter** key to store the new Odor Inlet High setting into memory. Press the **Down Arrow** key to advance to the next menu.

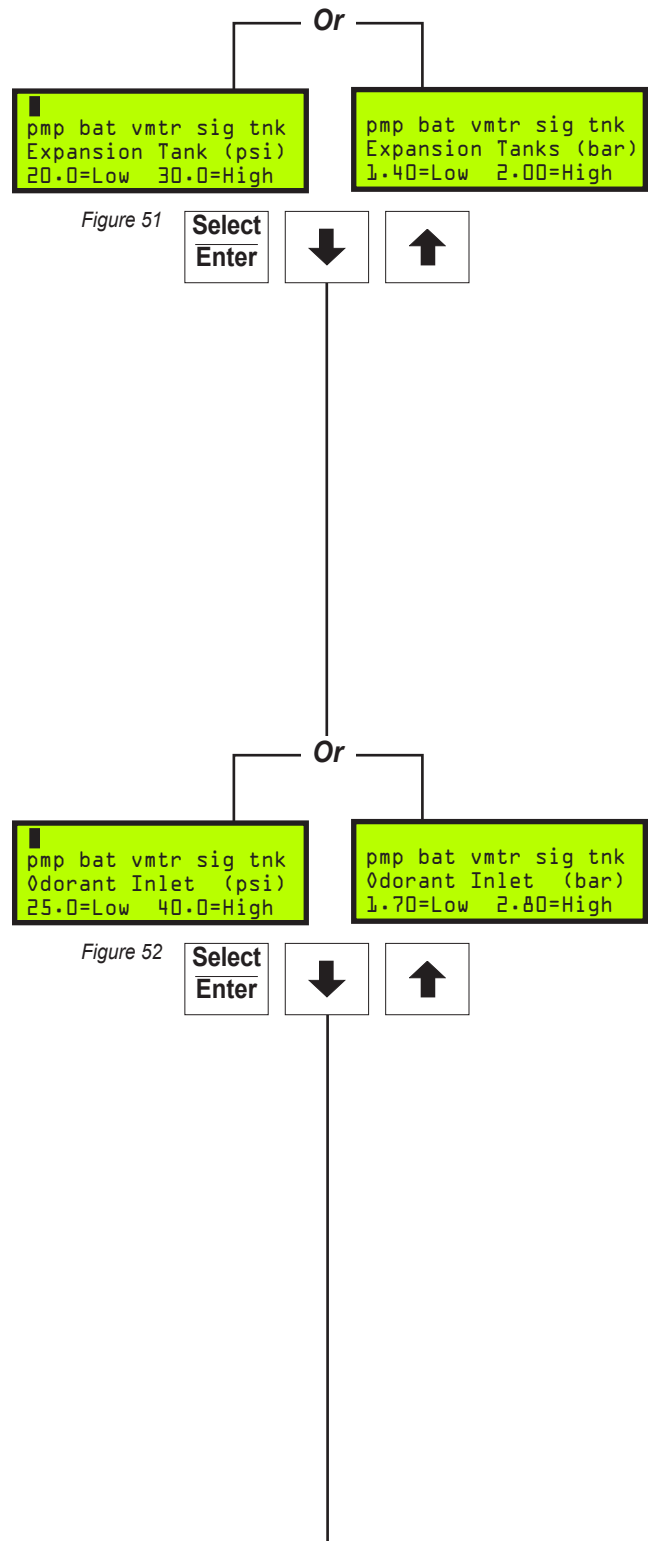

SECTION 5: PROGRAMMING FOR PROPORTIONAL-TO-FLOW OPERATION

Setting Operator Input Parameters,

Continued

Alarm to Relay Delay

Is a programmable time that can be entered to allow for a period of time to occur between the initial issuance of an alarm and the actual remote reporting of the alarm via the alarm relay output.

1. 0 = No Relay Contact Delay
2. 1 - 240 = Number of Minutes Delay
3. > 240 = Disabled, No Alarm Relay Contact will occur

To set the alarm delay time, *figure 53*, press and release the **Select** key. The Alarm to Delay value will begin to flash when chosen. Use the **Up Arrow** key to increase the value and the **Down Arrow** key to decrease the value. When a new value has been chosen, press the **Enter** key to store the value.

Alarm to Call Out Delay

Is a programmable time that can be entered to allow for a period of time to occur between the initial issuance of an alarm and the actual automatic call out function via a modem or Modbus communication port.

1. 0 = No Alarm Call Out Delay
2. 1 - 240 = Number of Minutes Delay
3. > 240 = Disabled, No Alarm Call Out will occur

To set the alarm to call out delay time, *figure 54*, press and release the **Select** key. The Alarm to Call-out Delay value will begin to flash when chosen. Use the **Up Arrow** key to increase the value and the **Down Arrow** key to decrease the value. When a new value has been chosen, press the **Enter** key to store the value.

MODBUS Address

In Modbus Protocol, each piece of equipment that will be polled for information must be assigned a Slave I.D. address, to allow the SCADA or other Host device to properly address the device to be polled for information. This parameter is to program the odorizer's Modbus address. Any address from 1-247 may be programmed. If 0 is programmed this function will be disabled, *figure 55*.

Note: the Modbus address is also used as the Sentry4 I.D.

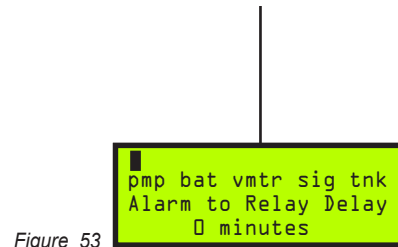

Figure 53

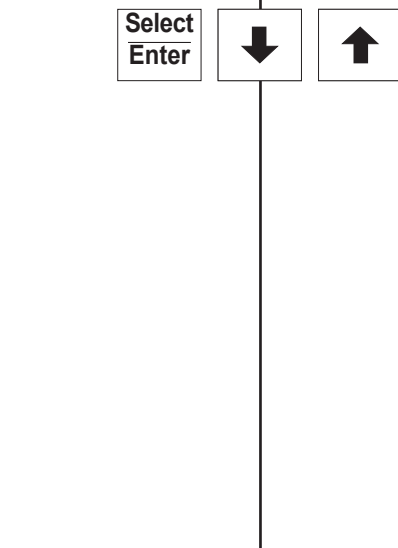

Figure 54

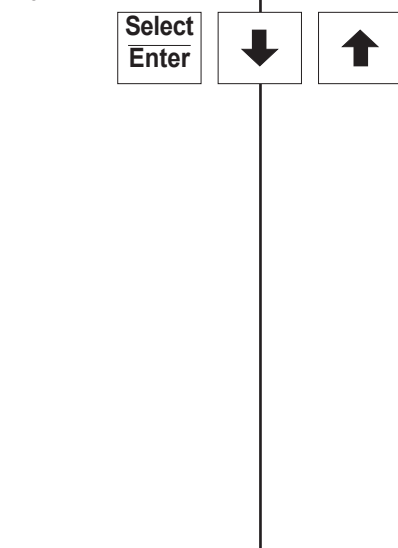

Figure 55

SECTION 5: PROGRAMMING FOR PROPORTIONAL-TO-FLOW OPERATION

MODBUS Parameters

There are 4 items of information that may be entered on this screen. They are baud, parity, framing mode, comm port designation, *figure 56*.

- 1st press the **Enter / Select** key and the baud rate window will begin to flash. Next use the **Up Arrow** or **Down Arrow** key to increment the value to the required baud rate of your Modbus system. Available baud rates are 1200, 2400, 4800, and 9600.
- Next press the **Enter / Select** key and the parity window will begin to flash. Next use the **Up Arrow** or **Down Arrow** key to increment the value to the required parity of your Modbus system. Parity options are odd, even, and none.
- The 3rd pressing of the **Enter / Select** key will bring you to the framing mode window will begin to flash. Next use the **Up Arrow** or **Down Arrow** key to increment the value to the required framing mode of your Modbus system. Available options are: RTU or ASCII.
- The final time you press the **Enter / Select** key, the comm port selection can be made. The N-300 has two comm ports. Use the **Up Arrow** or **Down Arrow** key to increment the value to select one of three options:

MODBUS Parameters

- COMM = . . ONLY Communications Port #2 will be available for communications using Sentry Software Communications Protocol.
- COMM = 1 . Communications Port #1 will be available for Modbus Communications, and Communications Port #2 will be available for communications using Sentry Software Communications Protocol.
- COMM = 1 2 Communications Port #1 and Communications Port #2 will be available for Modbus Communications, and NO ports will be available for communications using Sentry Software Communications Protocol.

Conclusion

This concludes programming the N-300G controller in Proportional-to-Flow Mode. If this NJEX System is the only unit that will be initialized at this time, [Section 7, page 39, Calibrating Signal Inputs](#), will contain the next appropriate information on the NJEX 7300 based on Proportional-to-Flow Mode operation. If other NJEX units will be operating in Proportional-to-Time Mode then proceed to the following Section 6.

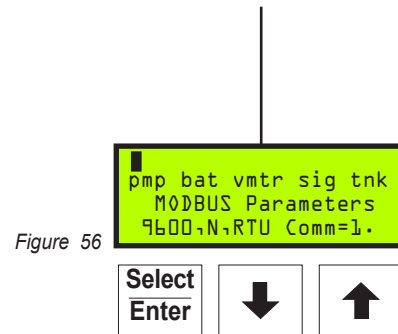

SECTION 6: PROGRAMMING FOR PROPORTIONAL-TO-TIME OPERATION

Setting Operator Input Parameters

Choose **Set** from the main menu, *figure 57*.

Choose **Par** from the set selection menu, *figure 58*.

Choose **Time** from the set parameters menu, *figure 59*.

Choose **Set** from the proportional-to-time menu, *figure 60*.

Pump displacement in cc/stroke

To set the pump displacement, *figure 61*, press and release the **Select** key. The value entry will begin to flash when chosen. Use the **Up Arrow** key to increase the value and the **Down Arrow** key to decrease the value. When a new value has been chosen, press the **Enter** key to store the new value into memory. The entered value will stop flashing when it has been loaded into memory. Press the **Down Arrow** key to advance to the next parameter.

Odorant density in lbs/gallon (g/cc.) @ 60°F

To set the odorant density, *figure 62*, press and release the **Select** key. The value entry will begin to flash when selected. Use the **Up Arrow** key to increase the value and the **Down Arrow** key to decrease the value. When a new value has been chosen, press the **Enter** key to store the new value into memory. The entered value will stop flashing when it has been loaded into memory. Press the **Down Arrow** key to advance to the next parameter.

Time interval between strokes of the pump in xx.xx minutes/stroke:

1. 0.00 minutes = proportional-to-time disabled.
2. 0.02 to 99.99 minutes = proportional-to-time enabled.

To set the time/strokes, *figure 63*, press and release the **Select** key. The value entry will begin to flash when chosen. Use the **Up Arrow** key to increase the value and the **Down Arrow** key to decrease the value.

**designates optional key function*

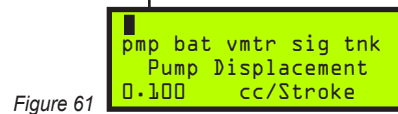
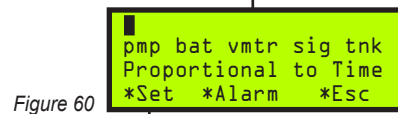
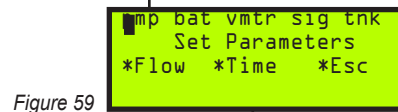
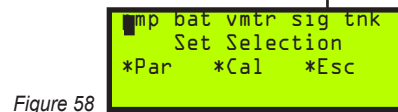
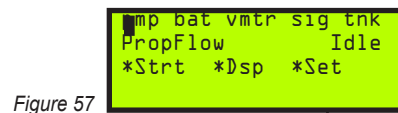

Or

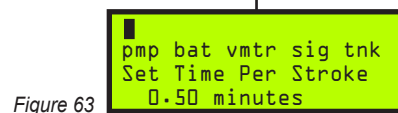
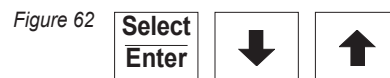
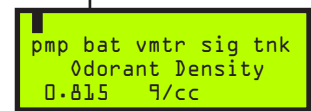
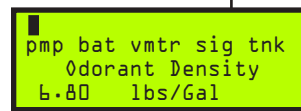

SECTION 6: PROGRAMMING FOR PROPORTIONAL-TO-TIME OPERATION

Setting Operator Input Parameters, *Continued*

When a new value has been chosen, press the **Enter** key to store the new value into memory. The entered value will stop flashing when it has been loaded into memory. Press the **Down Arrow** key to advance to the next parameter.

The Odorant Output Setting

This controls the scaling of the odorant output relay in lbs/pulse. This indicates how much odorant has been injected with each pulse of the output relay located **TB1**, terminals **#19** and **#20**, *refer to the Wiring Control Document on page 116 in Appendix D: Documents.*

To set the odorant output, *figure 64*, press and release the **Select** key. The value entry will begin to flash when selected. Use the **Up Arrow** key to increase the value and the **Down Arrow** key to decrease the value. When a new value has been chosen, press the **Enter** key to store the new value into memory. The entered value will stop flashing when it has been loaded into memory. Press the **Down Arrow** key to advance to the next parameter.

Odorant Tank

Optional Setup Note: *This parameter functions only if a complete YZ Skid Mounted Tank System is supplied.*

1. **Disabled:** no level monitoring, 0% = disabled, both Low & High settings must be disabled.
2. **Enabled:** 0-100% level monitoring with two alarms that may be triggered from this level reading, a High Tank Level Tank Alarm, and a Low Tank Level Tank Alarm.

To set the alarm level points, *figure 65*, press and release the **Select** key. The Low Level value will begin to flash when chosen. Use the **Up Arrow** key to increase the value and the **Down Arrow** key to decrease the value. This alarm should typically be set between 5% and 25%. When a new value has been chosen, press the **Enter** key to store the new Low Level Alarm setting into memory. The entered value will stop flashing when it has been loaded into memory, the High Level value will begin to flash. Use

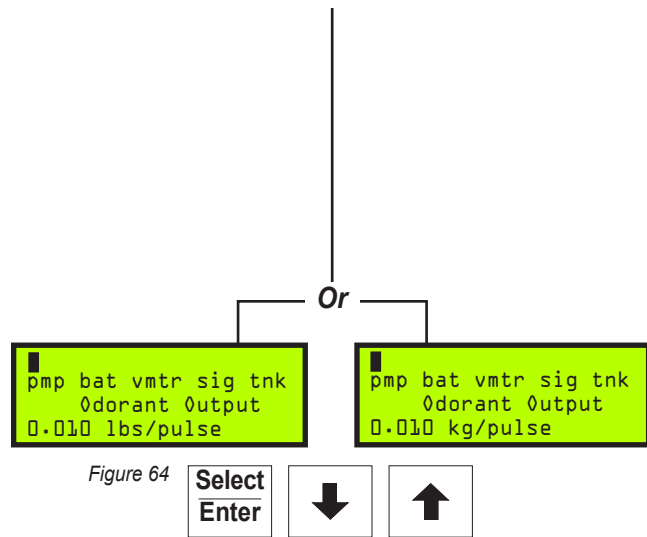
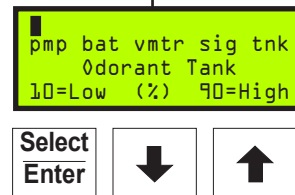

Figure 64

Figure 65



SECTION 6: PROGRAMMING FOR PROPORTIONAL-TO-TIME OPERATION

the **Up Arrow** key to increase the value and the **Down Arrow** key to decrease the desired value. This alarm should typically be set at less than 80%. When a new value has been chosen, press the **Enter** key to store the new High Level Alarm setting into memory. Press the **Down Arrow** key to advance to the next menu.

Expansion Tank Pressure Monitoring

The expansion tank pressure should typically remain at approximately 25 psi (1.72 Bar). There are two alarms that can be triggered a High Pressure Expansion Tank Alarm, and a Low Pressure Expansion Tank Alarm.

1. **Disabled:** no expansion tank pressure monitoring, 0 = disabled, Both Low & High settings must be disabled. Normal operation should have this function enabled.
2. **Enabled:** Low Level should typically be set @ 23 psi (1.58 Bar), but is adjustable from 0 psi (0 Bar) up to the high level set point. High Level should typically be set @ 27 psi (1.86 Bar), but is adjustable from 0 psi (0 Bar) up to 99 psi (6.82 Bar).

To set the alarm level points, figure 66, press and release the **Select** key. The Low Pressure value will begin to flash when chosen. Use the **Up Arrow** key to increase the value and the **Down Arrow** key to decrease the value. When a new value has been chosen, press the **Enter** key to store the new Low Pressure setting into memory. The entered value will stop flashing when it has been loaded into memory and the High Pressure value will begin to flash. Use the **Up Arrow** key to increase the value and the **Down Arrow** key to decrease the value. When a new value has been chosen, press the **Enter** key to store the new High Pressure setting into memory. Press the **Down Arrow** key to advance to the next menu.

Odorant Inlet Pressure Monitoring

In order for the fill valve to function correctly a pressure differential between the Bulk Odorant Storage Tank and the Expansion Tank, must be maintained. This differential should never be less than 5 psi (.35 Bar) and typically not more than 10 psi (.69 Bar). There are two alarms that can be triggered from the Odorant Inlet Pressure reading, a High Odorant Inlet Alarm, and a Low Odorant Inlet Alarm, figure 67.

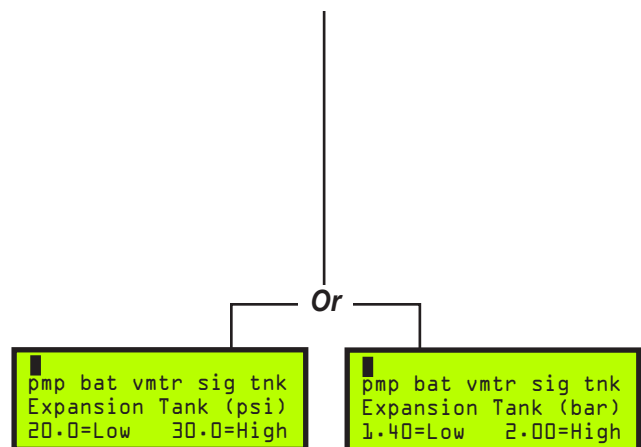

Figure 66

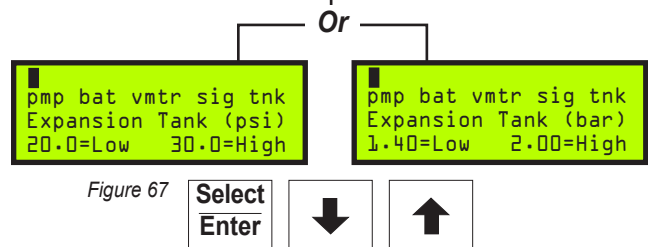

Figure 67

SECTION 6: PROGRAMMING FOR PROPORTIONAL-TO-TIME OPERATION

Setting Operator Input Parameters, *Continued*

To set the alarm level points, *figure 68*, press and release the **Select** key. The Odorant Inlet Low value will begin to flash when chosen. Nominal low pressure in the Odorant Storage Tank is 30 psi (2.07 Bar). Use the **Up Arrow** key to increase the value and the **Down Arrow** key to decrease the value. When a new value has been chosen, press the **Enter** key to store the new Odorant Inlet Low setting into memory. The entered value will stop flashing when it has been loaded into memory and the Odorant Inlet High value will begin to flash. Nominal high pressure in the Odorant Storage Tank is 35 psi (2.41 Bar). Use the **Up Arrow** key to increase the value and the **Down Arrow** key to decrease the value. When a new value has been chosen, press the **Enter** key to store the new Odorant Inlet High setting into memory. Press the **Down Arrow** key to advance to the next menu.

Alarm to Relay Delay

Is a programmable time that can be entered to allow for a period of time to occur between the initial issuance of an alarm and the actual remote reporting of the alarm via the alarm relay output.

1. 0 = No Relay Contact Delay
2. 1 - 240 = Number of Minutes Delay
3. > 240 = Disabled, No Alarm Relay Contact will occur

To set the alarm delay time, *figure 69*, press and release the **Select** key. The Alarm to Delay value will begin to flash when chosen. Use the **Up Arrow** key to increase the value and the **Down Arrow** key to decrease the value. When a new value has been chosen, press the **Enter** key to store the value.

Alarm to Call Out Delay

Is a programmable time that can be entered to allow for a period of time to occur between the initial issuance of an alarm and the actual automatic call out function via a modem or Modbus communication port.

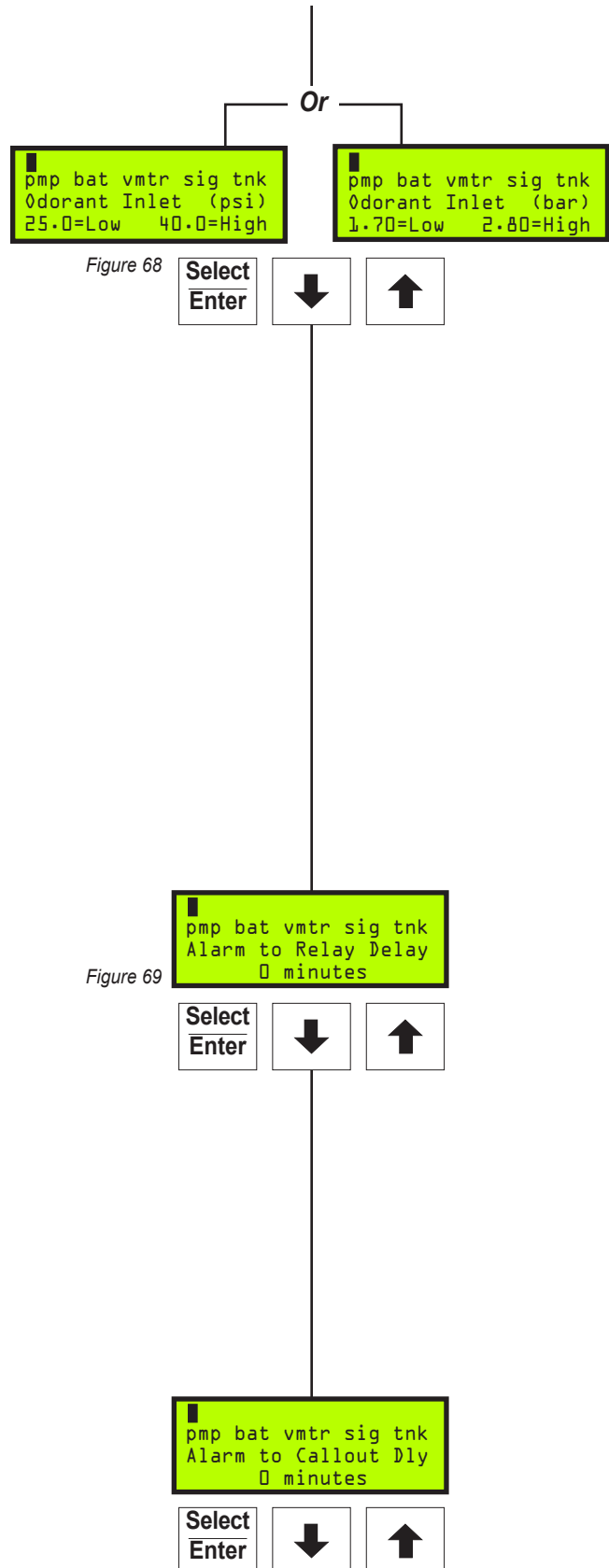

SECTION 6: PROGRAMMING FOR PROPORTIONAL-TO-TIME OPERATION

1. 0 = No Alarm Call Out Delay
2. 1 - 240 = Number of Minutes Delay
3. > 240 = Disabled, No Alarm Call Out will occur

To set the alarm to call out delay time, *figure 70*, press and release the **Select** key. The Alarm to Call-out Dly value will begin to flash when chosen. Use the **Up Arrow** key to increase the value and the **Down Arrow** key to decrease the value. When a new value has been chosen, press the **Enter** key to store the value.

MODBUS Address

In Modbus Protocol, each piece of equipment that will be polled for information must be assigned a Slave I.D. address, to allow the SCADA or other Host device to properly address the device to be polled for information. This parameter is to program the odorizer's Modbus address. Any address from 1-247 may be programmed. If 0 is programmed this function will be disabled, *figure 71*.

Note: the Modbus address is also used as the Sentry4 I.D.

MODBUS Parameters

There are 4 items of information that may be entered on this screen. They are baud, parity, framing mode, comm port designation, *figure 72*.

- 1st press the **Enter / Select** key and the baud rate window will begin to flash. Next use the **Up Arrow** or **Down Arrow** key to increment the value to the required baud rate of your Modbus system. Available baud rates are 1200, 2400, 4800, and 9600.
- Next press the **Enter / Select** key and the parity window will begin to flash. Next use the **Up Arrow** or **Down Arrow** key to increment the value to the required parity of your Modbus system. Parity options are odd, even, and none.
- The 3rd pressing of the **Enter / Select** key will bring you to the framing mode window will begin to flash. Next use the **Up Arrow** or **Down Arrow** key to increment the value to the required framing mode of your Modbus system. Available options are: RTU or ASCII.
- The final time you press the **Enter / Select** key, the comm port selection can be made. The N-300 has two comm ports. Use the **Up Arrow** or **Down Arrow** key to increment the value to select one of three options:

Figure 70

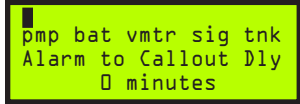

```
pmp bat vmtr sig tnk
Alarm to Callout Dly
0 minutes
```



Figure 71

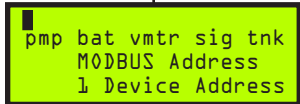

```
pmp bat vmtr sig tnk
MODBUS Address
1 Device Address
```



Figure 72

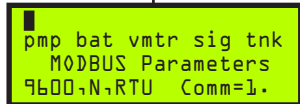

```
pmp bat vmtr sig tnk
MODBUS Parameters
9600-N-RTU Comm=1
```



SECTION 6: PROGRAMMING FOR PROPORTIONAL-TO-TIME OPERATION

Setting Operator Input Parameters, *Continued*

MODBUS Parameters, *Continued*

COMM = . . ONLY Communications Port #2 will be available for communications using Sentry Software Communications Protocol.

COMM = 1 . Communications Port #1 will be available for Modbus Communications, and Communications Port #2 will be available for communications using Sentry Software Communications Protocol.

COMM = 1 2 Communications Port #1 and Communications Port #2 will be available for Modbus Communications, and NO ports will be available for communications using Sentry Software Communications Protocol.

Conclusion

This concludes programming the N-300G controller in Proportional-to-Time Mode. If the NJEX 6300 System is the only unit that will be initialized at this time the following Section 7, Calibrating Signal Inputs will contain the next appropriate information based on Proportional-to-Time Mode operation.

SECTION 7: CALIBRATING SIGNAL INPUTS

Analog Flow Input Calibration, 1-5 VDC / 4-20 mA

IMPORTANT:

Many factors effect the signal between the signal source and the NJEX System. Elements of the signal electrical system such as the gauge and length of the wire, isolation barrier, grounding, transient voltages, and the condition of the signal generated by the flow device can effect the signal and how that signal is received by the NJEX System. To truly calibrate the NJEX System to the signal, use only the flow equipment that will be part of the odorization system such as; a flow computer, RTU, PLC, pulse index drive, or differential pressure transducer.

Choose ***Set** in the main menu, *figure 73*.

Choose ***Cal** in the set selection menu, *figure 74*.

Choose ***Inputs** in the calibration set menu, *figure 75*.

Choose ***Flow** in the calibration selection menu, *figure 76*.

Choose ***Ang** in the flow input type menu, for analog voltage or current inputs, i.e., 1-5VDC or 4-20mA, *figure 77*.

Choose ***Lin** for input signals that are linear with respect to flow i.e., flow computers, RTU's, etc, *figure 78*.

-OR-

Choose ***NonLin** for input signals that are non-linear with respect to flow i.e., differential pressure transmitters, etc., *figure 78*.

Choose ***Zero** to calibrate the zero set point, *figure 79*.

Zero Adjustment, *figure 80*, is used to calibrate the N-300G controller for 0% of the metered flow in the pipeline. The N-300G is factory calibrated for 0% of flow to directly correspond to 1.00 VDC (4.0 mA) at the flow input terminal board **TB1** terminals **#2** and **#3**, refer to the [Wiring Control Document on page 116 in Appendix D: Documents](#).

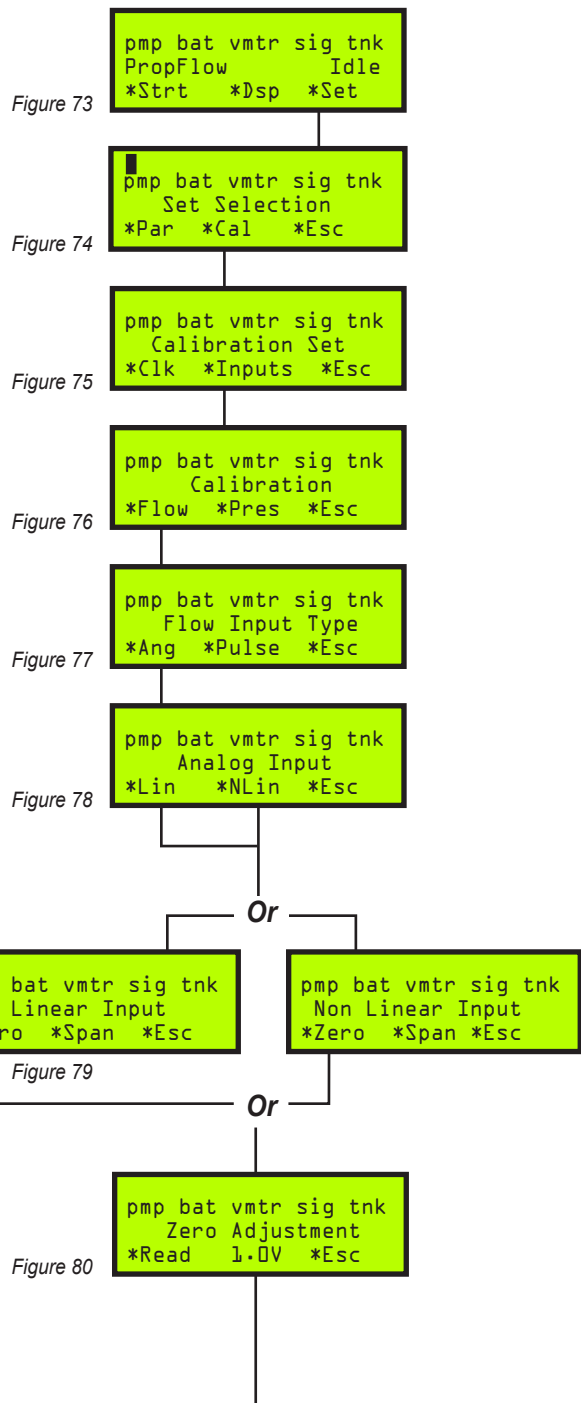

SECTION 7: CALIBRATING SIGNAL INPUTS

Analog Flow Input Calibration, 1-5 VDC / 4-20 mA, *Continued*

To calibrate the zero set point, *figure 81*, apply 1.00 VDC (4.0 mA) to the TB1 terminal #2 (+ positive signal input) and terminal #3 (- negative signal input). If a Differential Pressure Transducer – DPT is used, output from the transmitter should be 1.00 VDC (4.0mA) at 0 inches of water column differential (0" w.c.).

1. Press & release the ***Read** key and the voltage present at the input terminals will be shown flashing in the display.
2. Press & release the ***Accept** key to load the zero point into the memory. This value will stop flashing when this is completed, *figure 82*.

Note: if an error message appears, *figure 83*, the voltage at the input terminal is outside of the calibration range of .6V -1.4VDC (2.4 mA - 5.6 mA).

Choose Span to calibrate the full span set point, *figure 84*, the span adjustment is used to calibrate the N-300G controller for 100% of metered flow in the pipeline. The N-300G is factory calibrated for 100% of flow to directly correspond to 5.00 VDC (20 mA) at the flow input terminal board TB1 terminals #2 and #3, [refer to the Wiring Control Document on page 116 in Appendix D: Documents](#).

To calibrate the span set point, apply 5.00 VDC (20 mA) to TB1 terminal #2 (+ positive signal input) and terminal #3 (- negative signal input). If a DPT is used, output from the transmitter should be 5.00 VDC (20 mA) at maximum range of the meter, for example 5.00 VDC (20 mA) at 100 inches of water column differential (100" w.c.).

1. Press & release the ***Read** key and the voltage present at the input terminals will be shown flashing in the display, *figure 85*.
2. Press & release the ***Accept** key to load the span setting into the memory. This value will stop flashing when this is completed, *figure 86*.

Note: if an error message appears, *figure 87*, the voltage at the input terminal is outside of the calibration range of 3.0V-5.5VDC (12 mA - 22 mA).

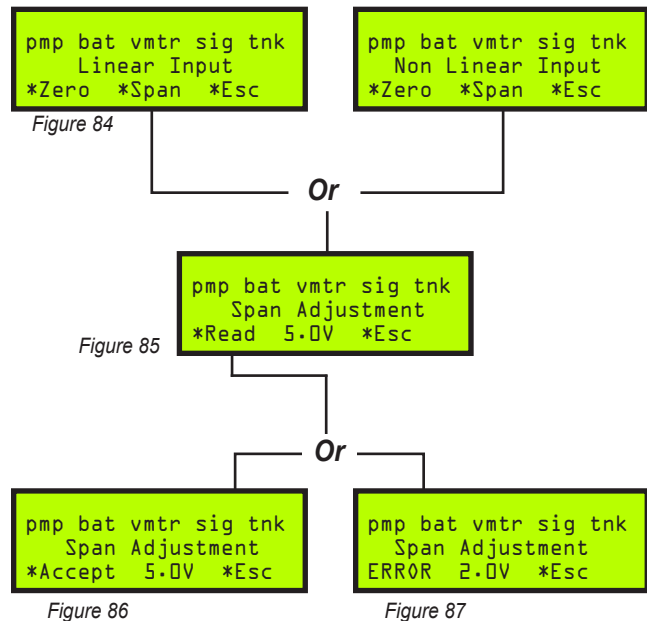
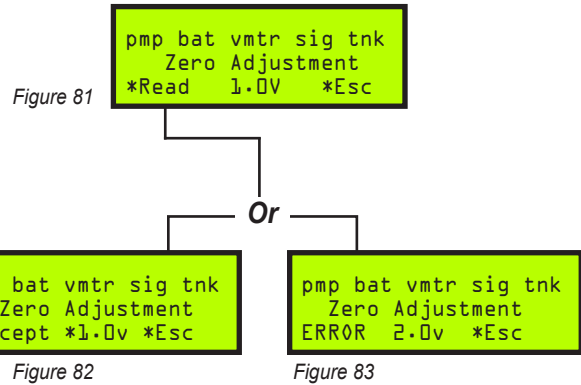

SECTION 7: CALIBRATING SIGNAL INPUTS

Expansion Tank Pressure Transmitter Zero Calibration

Note: the N-300G should be in the stopped mode when performing the following calibrations.

Choose ***Set** in the main menu, *figure 88*.

Choose ***Cal** in the set selection menu, *figure 89*.

Choose ***Inputs** in the calibration set menu, *figure 90*.

Choose ***Pres** in the calibration menu, *figure 91*.

Choose ***XTank** in the Calibrate Pressure menu. The transmitter voltage is 1-5VDC. The only field calibration is the zero reference, which can be set in this display, *figure 92*.

Zero Adjustment, is used to calibrate the N-300G controller to a zero pressure reference point. The transmitter is factory calibrated for the span value referenced to a specific pressure above this set point.

To calibrate the zero set point, remove all pressure from the expansion tank by venting the expansion tank pressure via valve V-5. The output from the transmitter should be 1.00 VDC.

1. Press & release the ***Read** key, *figure 93*, and the actual voltage present from the transmitter will be shown flashing in the display.
2. Press & release the ***Accept** key, *figure 94*, to load the zero point into the memory. This value will stop flashing when this is accomplished.

Note: if an error message appears, *figure 95*, the voltage is outside of the calibration range of .6V-1.4VDC.

3. If the odorant inlet transmitter requires zero calibration at this time, proceed to the [Odorant Inlet Pressure Transducer Zero Calibration on page 42](#) prior to pressurizing the expansion tank.

- 3a. **Important**, If the odorant inlet transmitter is not to be zero calibrated at this time, close **V5** and adjust the expansion tank pressure back to 25 psi (1.72 Bar), by manually opening valve **V4** until the proper pressure is obtained, then close **V4**.

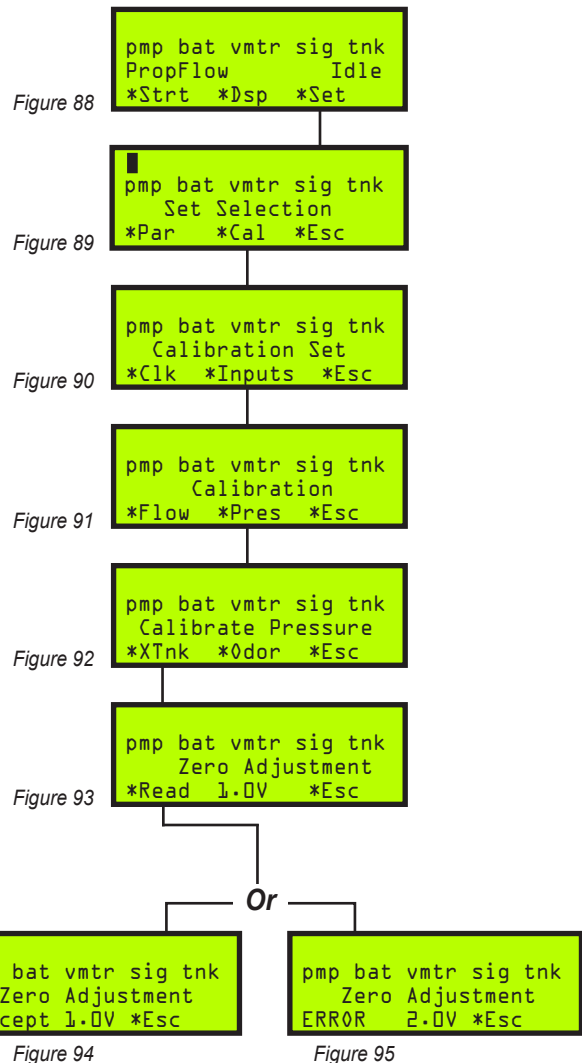

SECTION 7: CALIBRATING SIGNAL INPUTS

Odorant Inlet Pressure Transmitter Zero Calibration

Note: the N-300G should be in the stopped mode when performing the following calibrations.

Choose ***Set** in the main menu, *figure 96*.

Choose ***Cal** in the set selection menu, *figure 97*.

Choose ***Inputs** in the calibration set menu, *figure 98*.

Choose ***Pres** in the calibration section menu, *figure 99*.

Prior to performing the odorant inlet transmitter calibration, remove all pressure from the odorant inlet by:

- Verifying that the verometer is not at the full level.
- Close **V8**.
- Close the Odorant Supply Valve **V17**, located at the Bulk Odorant Filter inside of the enclosure.
- If the expansion tank has pressure in it, remove it by venting the expansion tank pressure via **V5**.
- Open **V3**.
- In the display screen tell the verometer to fill.
- This should bring the transmitter pressure to zero.

Choose ***Odor** in the Calibrate Pressure menu, *figure 100*. The transmitter voltage is 1-5VDC. The only field calibration is the zero reference, which may be set here.

Zero Adjustment, *figure 101*, is used to calibrate the N-300G controller to a zero pressure reference point. The transmitter is factory calibrated for the span value referenced to a specific pressure above this set point.

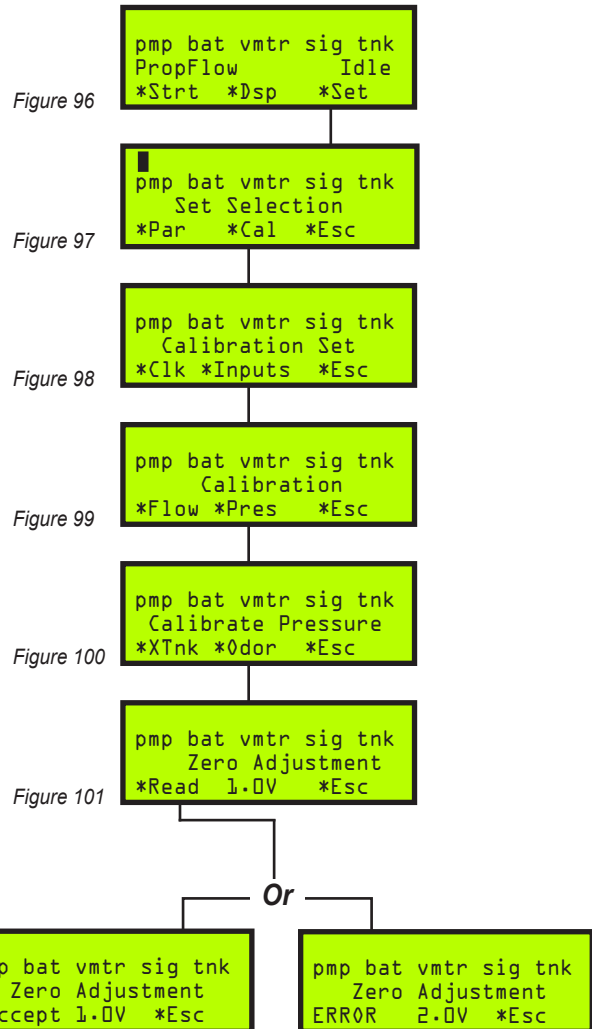

SECTION 7: CALIBRATING SIGNAL INPUTS

To calibrate the zero set point, The output from the transmitter should be 1.00 VDC.

1. Press & release the ***Read** key and the actual voltage present from the transmitter will be shown flashing in the display, *figure 102*.
2. Press & release the ***Accept** key to load the zero point into the memory. This value will stop flashing when this is accomplished, *figure 103*.

Note: if an error message appears, *figure 104*, the voltage is outside of the calibration range of .6V-1.4VDC.

Return all valves and pressures to normal settings before restarting the system.

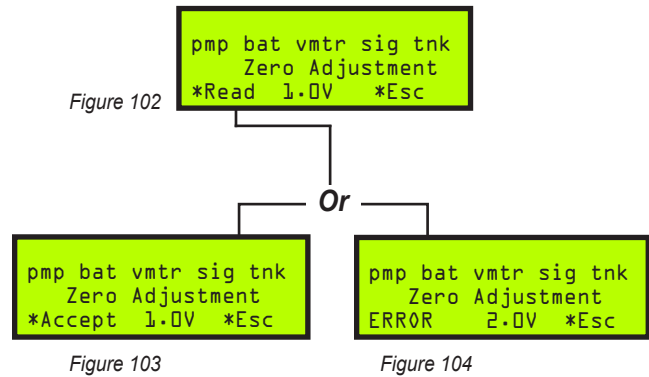

SECTION 7: CALIBRATING SIGNAL INPUTS

Pulse Flow Input Calibration, Dry Contact & Voltage Pulse

Choose ***Set** from the main menu, *figure 105*.

Choose ***Cal** from the set select menu, *figure 106*.

Choose ***Inputs** from the calibration set menu, *figure 107*.

Choose ***Flow** from the flow input type menu, *figure 108*.

Choose ***Pulse** from the flow input type menu for digital pulse inputs, i.e. dry contact, voltage pulse, etc, *figure 109*.

Calculate Pulse Input Frequency

Using [the example contained in Figure 113 on page 45](#) a technician can calculate the Pulse Input Frequency required to effectively calibrate the NJEX System.

If the pulse input frequency is between 1-1000 pulses per second (Hz), choose PPS, *figure 110*.

-OR-

If the pulse input frequency is between 1-100 pulses per minute, choose PPM, *figure 110*.

Span Adjustment, is used to calibrate the N-300G controller for 100% of metered flow at maximum input frequency, i.e. 100 pulses per second at maximum gas flow.

To set the span adjustment, *figure 111 & 112*, press and release the **Select** key. The value entry will begin to flash when it is chosen. Use the **Up Arrow** key to increase the value and the **Down Arrow** key to decrease the value. When a new value has been chosen press the **Enter** key to store the value into memory. The value entry will stop flashing when loaded into the memory.

Figure 105
pmp bat vmtr sig tnk
PropFlow Idle
*Strt *Dsp *Set

Figure 106
pmp bat vmtr sig tnk
Set Selection
*Par *Cal *Esc

Figure 107
pmp bat vmtr sig tnk
Calibration Set
*Clk *Inputs *Esc

Figure 108
pmp bat vmtr sig tnk
Calibration
*Flow *Pres *Esc

Figure 109
pmp bat vmtr sig tnk
Flow Input Type
*Ang *Pulse *Esc

Figure 110
pmp bat vmtr sig tnk
Pulse Input Scan
*PPS *PPM *Esc

Figure 111
pmp bat vmtr sig tnk
Span Adjustment
50 Pul/sec *Esc

Figure 112
pmp bat vmtr sig tnk
Span Adjustment
30 Pul/min *Esc

SECTION 7: CALIBRATING SIGNAL INPUTS

Figure 113

Calculation for Determining the Span Frequency

$$\frac{\text{Pulse}}{\text{CF}} \times \begin{array}{c} \uparrow \\ \text{max flow rate} \end{array} \frac{\text{CF}}{\text{Hr}} = \frac{\text{Pulses}}{\text{Hr}}$$

As determined by the flow metering device

Example:

$$\frac{1 \text{ pulse}}{10\text{CF}} \times \frac{1,000,000\text{CF}}{\text{Hr}} = 100,000 \text{ pulses/hr}$$

Since pulses per hour is not an option for programming the N-300G divide by 60 minutes per hour to obtain pulses per minute.

$$\frac{100,000 \text{ pulses}}{\text{Hr}} \times \frac{1\text{Hr}}{60 \text{ min.}} = 1,666.7 \text{ pulses/min.}$$

Since a maximum of 100 pulses per minute may be programmed into the N-300G, you must now divide by 60 seconds per minute to obtain pulses per second, if this value had calculated to less than 100 pulses per minute it could have been programmed into the N-300G.

$$\frac{1,666.7 \text{ pulses}}{\text{min.}} \times \frac{1 \text{ min.}}{60 \text{ sec}} = 27.7 \text{ pulses/sec.}$$

Select PPS and set the span to 28 pulses per second.

SECTION 8: WORKING WITH THE N-300 SYSTEM DISPLAYS

Display Functionality

Characters in the display will change to indicate the varying conditions of NJEX System operation. As discussed in [Section 1: First Things to Know, Typographic Conventions, page 1](#) and in [Section 4: System Control and Electronics, page 19](#) the display interacts with the keyboard to access the different levels or areas in the programming function of the N-300 controller.

That extra-functionality in the display plays a further roll in the case of Alarm Indicators and Non-Alarm Indicators.

With the activation of an alarm indicator, the alarm function of the NJEX System turns into an **UPPER CASE** character set. For example, **pmp** – pump, becomes **PMP** indicating that an alarm is active, [figure 114](#).

To indicate the specific activity of the alarm, the N-300 will flash a description, and solid black box – , in the top line of the display, [figure 115](#).

The character change indicating that a monitored condition is in alarm status is further accompanied by a flashing LED light. Any time an alarm is simulated or real, a bright red LED light will flash in the alarm light indicator, located just below the **Select / Enter** key. Any time a non-alarm is simulated or real, a bright green LED light will flash in the indicator light indicator, located just below the **Down Arrow** key, [figure 116](#).

Further discussion of the display functions can be found under the [Setting & Testing Alarms, Section 9 beginning with page 53](#).

Figure 114



Figure 115

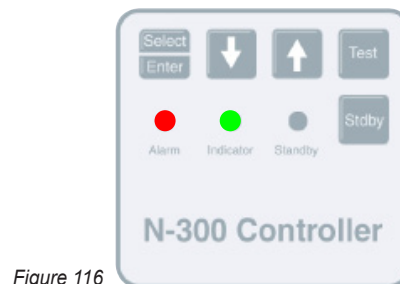
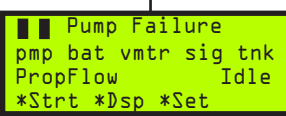

SECTION 8: WORKING WITH THE N-300 SYSTEM DISPLAYS

To View Real Time Displays

Choose *Dsp in the main menu, *figure 117*.

Strokes signaled are the number of pump strokes signaled by the N-300G controller are shown in this display, *figure 118*.

To reset strokes signaled, press the *Rst key and follow instructions, *figures 119*.

Odorant Injected, *figure 120*, is the cumulative total of odorant injected in lbs. (kg) is shown in this display.

To reset lbs. (kg) injected, *figures 121*, press the *Rst key and follow instructions.

Note: Pounds – lbs. (kg) injected will increment only when a valid pump displacement has been calculated. Pounds – lbs. (kg) injected will not increment during fill valve alarm condition.

Pump Displacement

This display illustrates the last value, in cc / stroke, calculated by the N-300G with volume data supplied by the Verometer, *figure 122*.

Note: an asterisk "*" following the value illustrated in the display designates that a value has not been calculated at present, and the previously set or programmed pump displacement will be displayed, refer to the [Programming Sections 5 & 6, beginning on pages 25 & 33](#).

Pump Alarms

There are three conditions that will result in a pump alarm indication.

- **Over Pumping**, *figure 123*, the calculated pump displacement exceeds the set pump displacement by 30%.
- **Under Pumping**, *figure 124*, the calculated pump displacement is less than the set pump displacement by 30%.
- **Pump Failure**, *figure 125*, the calculated pump displacement is less than the set pump displacement by 75%. For example, low displacement due to an empty meter, the pump cannot inject odorant when required if the meter which supplies the odorant to the pump is empty.

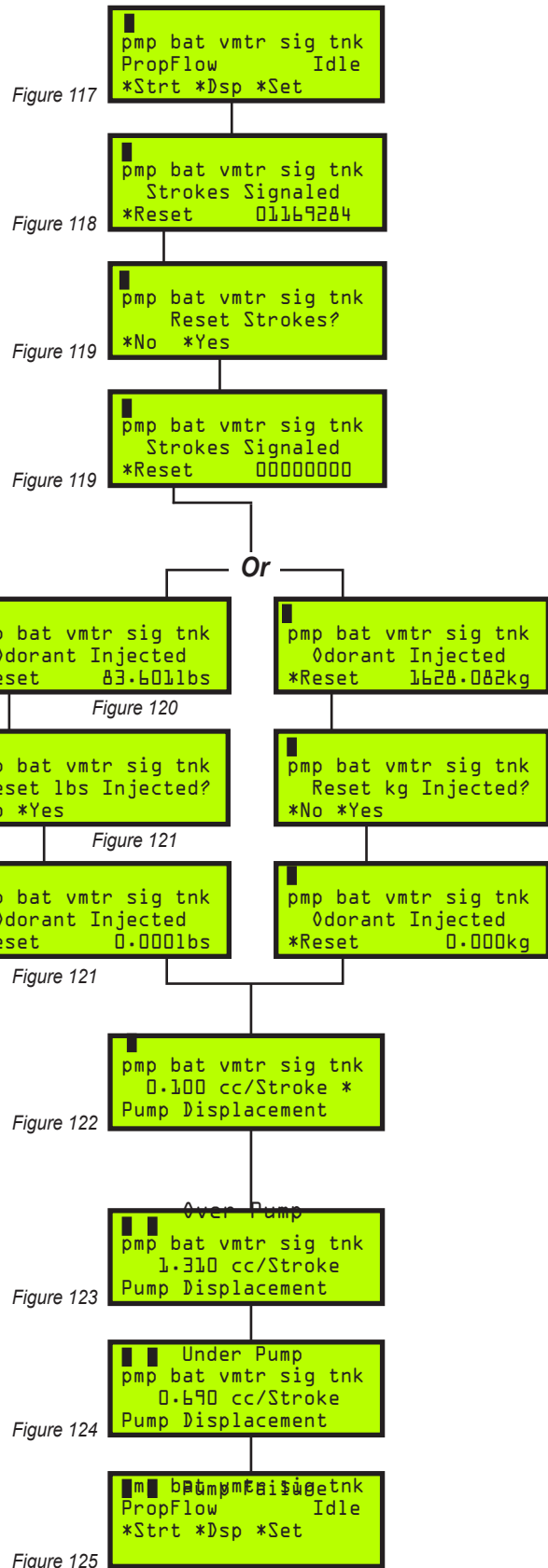

SECTION 8: WORKING WITH THE N-300 SYSTEM DISPLAYS

Meter Level – Verometer

This display illustrates the Verometer level in percent. As odorant is pumped out of the Verometer, the N-300G controller will automatically refill the meter when the meter level reaches 0%, *figure 126*.

To manually fill the Verometer, *figure 127*, press the *Fill key and follow the instructions. The following represent There conditions that will result in a meter alarm indication.

Meter Alarms – Verometer

These are of the displays containing 12 alarm and non-alarm indicators, *figures 128*, to provide information on Verometer operation.

- **Vmtr-Cable**, the Verometer cable is not communicating to the controller.
- **No Fill**, the meter has failed to fill.
 - a. The meter has failed to fill to 100% within six minutes
 - b. The fill was inhibited due to leakage detection
- **Slow Fill**, the meter has failed to fill within three minutes.
- **Fill Valve**, the fill valve has failed to close.
- **OdorInlet-Cable**, inlet fill valve pressure transmitter is not communicating with the controller.
- **OdorInlet Lo**, the required inlet pressure of odorant is lower than allowed.
- **OdorInlet Hi**, the required inlet pressure of odorant is higher than allowed
- **XTank-Cable**, the expansion tank cable outlet fill valve pressure transmitter is not communicating with the controller.
- **XTank Low**, the expansion tank pressure has fallen below the programmed low-pressure setting.
- **XTank Hi**, the expansion tank pressure has risen above the programmed high-pressure setting.

Meter Indicators, non-alarm

- **Over Fill**, the meter has been filled in excess of 112%.
 - a. The Verometer Fill Rate is too fast, in excess of 10 seconds.
 - b. The verometer Fill Valve has failed to close.
- **Fill Rate**, the meter has filled too fast, in excess of 10 seconds.

Figure 126

```
pmp bat vmtr sig tnk
Meter Level 00.0%
*Fill
```

Figure 127

```
pmp bat vmtr sig tnk
Fill Verometer?
*No *Yes
```

```
pmp bat vmtr sig tnk
Meter Level 100.0%
*Fill
```

Figure 128

```
Umtr-Cable
pmp bat VMTR sig tnk
Meter Level 0.0%
*Fill
```

Figure 128

```
No Fill
pmp bat VMTR sig tnk
Meter Level 0.0%
*Fill
```

Figure 128

```
Slow Fill
pmp bat VMTR sig tnk
Meter Level 0.0%
*Fill
```

Figure 128

```
Flvalve-Fail
pmp bat VMTR sig tnk
Meter Level 106.1%
*Fill
```

Figure 128

```
OdorInlet-Cabl
pmp bat VMTR sig tnk
Meter Level 99.6%
*Fill
```

Figure 128

```
Odor Inlet-Low
pmp bat VMTR sig tnk
Meter Level 99.6%
*Fill
```

Figure 128

```
Odor Inlet-Hi
pmp bat VMTR sig tnk
Meter Level 99.6%
*Fill
```

Figure 128

```
XTank-Cable
pmp bat VMTR sig tnk
Meter Level 99.6%
*Fill
```

Figure 128

```
XTank-Low
pmp bat VMTR sig tnk
Meter Level 99.6%
*Fill
```

Figure 128

```
XTank-High
pmp bat VMTR sig tnk
Meter Level 99.6%
*Fill
```

Figure 128

```
Over-fill
pmp bat VMTR sig tnk
Meter Level 104.3%
*Fill
```

Figure 128

```
Fillrate
pmp bat VMTR sig tnk
Meter Level 104.3%
*Fill
```

SECTION 8: WORKING WITH THE N-300 SYSTEM DISPLAYS

To View Real-Time Displays, *Continued*

Expansion Tank

This display illustrates the expansion tank pressure, *figure 129*.

Odorant Inlet

Displays the pressure of the bulk odorant storage tank via the pressure transmitter located at the fill rate control valve, *figure 130*.

Battery Voltage

The battery voltage is shown in this display, *figures 131*.

- **Battery Alarm**, a low battery is when the voltage is less than 11.5 VDC.

Flow Input

This display, *figure 132*, illustrates the flow rate as a percentage of the maximum gas flow. The following represent the alarms that are associated with this area of the N-300G controller.

Flow Input Alarms

- **Loss of Signal**, *figure 133*, the flow signal is less than .5 VDC, for the analog input only.
- **Over Flow**, *figure 134*, the flow input has exceeded 125% of the maximum gas flow.

Flow Input Indicators, non-alarm

- **Low Flow**, *figure 135*, the flow input has fallen below the low flow shut off set point [refer to Section 5, Programming for Proportional-to-Flow page 26](#).
- **Over Flow**, *figure 136*, the flow input has exceeded 110% of the maximum gas flow, but is still less than 125% of maximum gas flow.
- **No Flow**, *figure 137*, is presently indicated by the flow signal.
- **Low Flo Shtoff**, *figure 138*, the flow signal indicates a flow rate less than programmed for odorization.

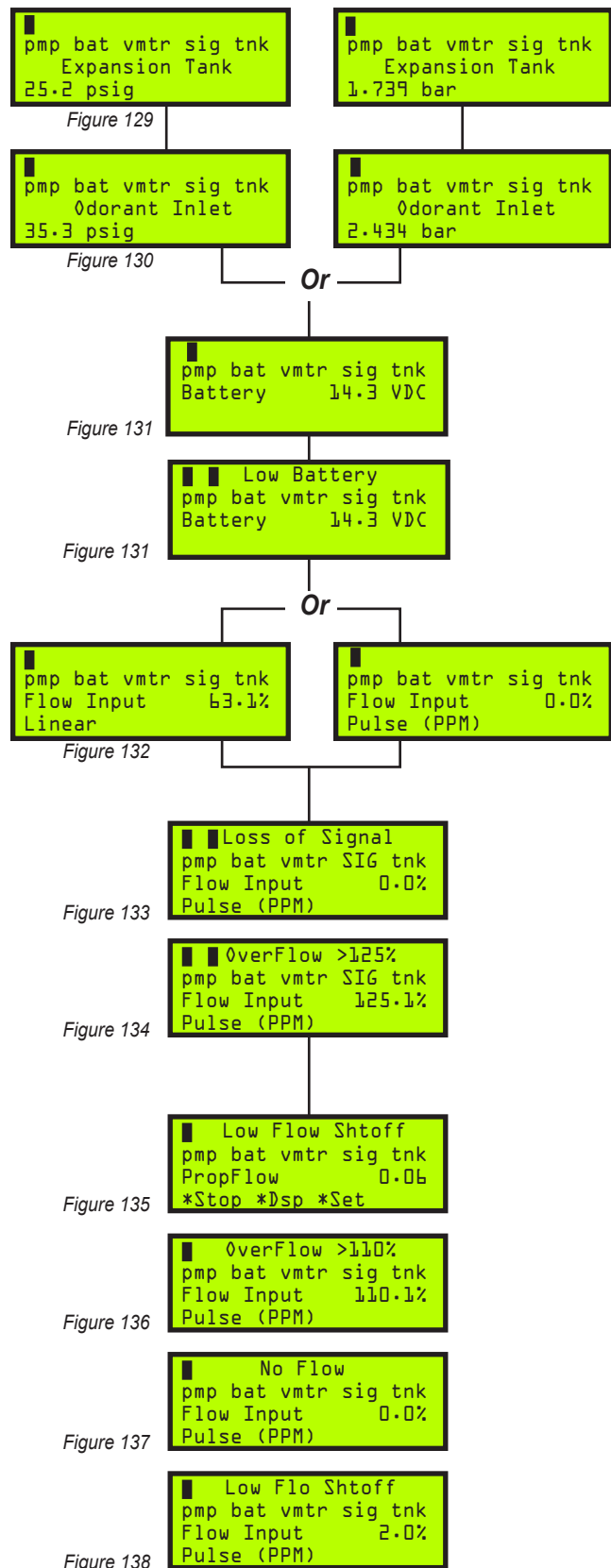

SECTION 8: WORKING WITH THE N-300 SYSTEM DISPLAYS

Note: the flow input display is active in the Proportional-to-Flow mode only.

Tank Level

This display, *figure 139*, illustrates the odorant supply level in the bulk odorant storage tank.

Note: The tank level indication is active only when there is a YZ supplied tank.

Tank Level Alarm

- **Low Level**, *figure 140*, the odorant supply tank level has fallen below the low level set point, [refer to Programming for Proportional-to-Flow and Programming for Proportional-to-Time Sections 5 & 6, pages 28 & 34.](#)
- **High Level**, *figure 141*, the odorant supply tank level rises above the high level set point, [refer to Programming for Proportional-to-Flow and Programming for Proportional-to-Time Sections 5 & 6, pages 28 & 34.](#)

Note: the tank level display is only active when it is not disabled (>00% = Low & High Level).

Odorant Temperature

This display, *figure 142*, illustrates the odorant temperature, time and date.

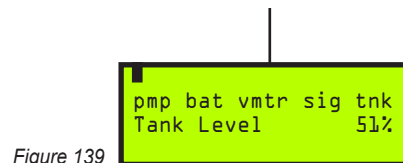

Figure 139

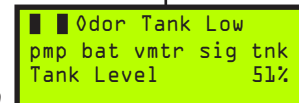

Figure 140

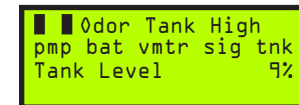

Figure 141

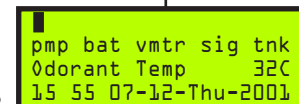

Figure 142

SECTION 9: SETTING & TESTING ALARMS

Setting Alarm Out Status

Alarm outputs can be configured to enable or disable which alarms deactivate the alarm output contact located on **TB1**, terminals **#17** and **#18**, refer to the [Wiring Control Document on page 116 in Appendix D: Documents](#). Only an entire alarm area may be disabled for example, pump alarms.

CAUTION:

Alarm outputs are critical for monitoring system performance. Outputs should not be disabled except for testing/troubleshooting.

Choose ***Set** in the main menu, *figure 143*.

Choose ***Par** – parameters in the Set Selection menu, *figure 144*.

Choose ***Flow** or ***Time** in the Set Parameters menu, *figures 145*.

Choose ***Alarm** from the Proportional-to-Time or Proportional-to-Flow menu, *figure 146*.

Choose ***Set** from the Alarm Out Status menu, *figure 147*.

To set the pump alarm status, *figure 148*, press and release the **Select** key. The entered value will flash when it is chosen. Use the **Down Arrow** or **Up Arrow** keys to change the setting. Press the **Enter** key to load the entry into memory. The display will stop flashing when the entered value is loaded into the memory. Press the **Down Arrow** key to advance to the next parameter.

To set the battery alarm status, *figure 149*, press and release the **Select** key. The entered value will begin to flash when chosen. Use the **Up Arrow** or **Down Arrow** keys to change the value. When a new value has been chosen, press the **Enter** key to store the new value into memory. The entered value will stop flashing when it has been loaded into memory. Press the **Down Arrow** key to advance to the next parameter.

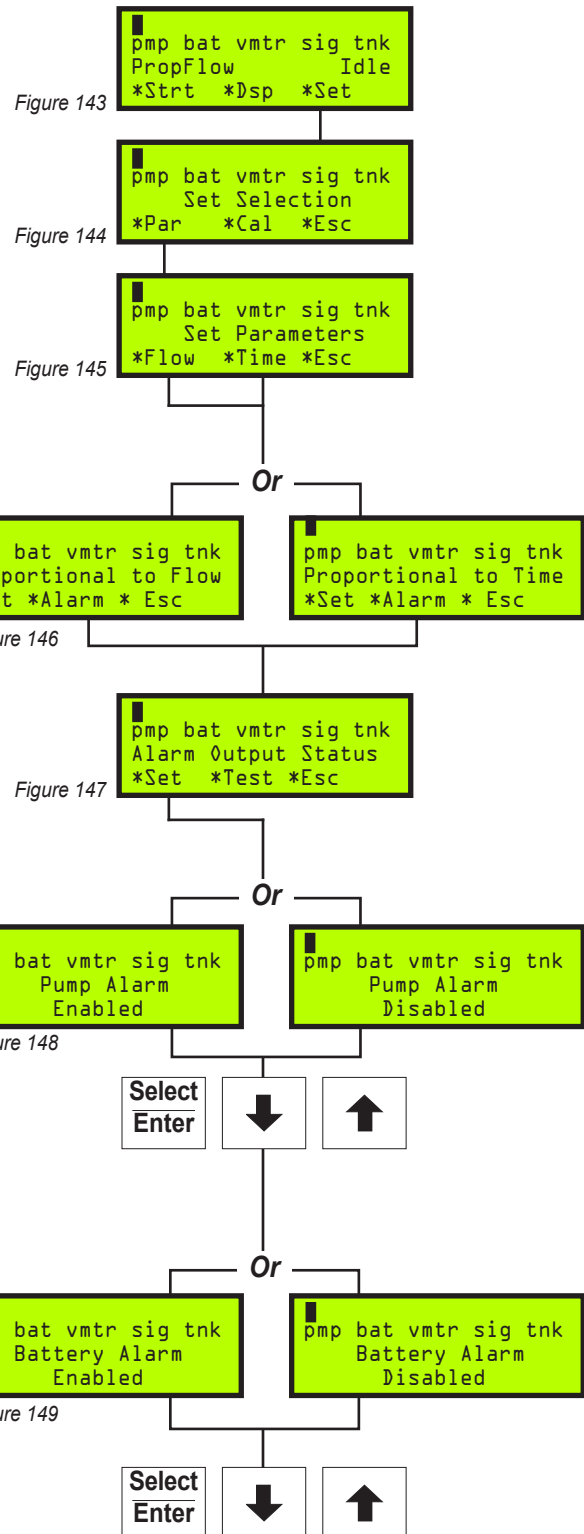

SECTION 9: SETTING & TESTING ALARMS

Setting Alarm Out Status,

Continued

To set the Verometer alarm status, *figure 150*, press and release the **Select** key. The entered value will begin to flash when chosen. Use the **Up Arrow** or **Down Arrow** keys to change the value. When a new value has been chosen, press the **Enter** key to store the new value into memory. The entered value will stop flashing when it has been loaded into memory. Press the **Down Arrow** key to advance to the next parameter.

To set the Signal alarm status, *figure 151*, press and release the **Select** key. The entered value will begin to flash when chosen. Use the **Up Arrow** or **Down Arrow** keys to change the value. When a new value has been chosen, press the **Enter** key to store the new value into memory. The entered value will stop flashing when it has been loaded into memory. Press the **Down Arrow** key to advance to the next parameter.

Note: this alarm window option will only display if you have chosen the *Proportional-to-Flow* path.

Note: this option should only be active if your system was supplied with a YZ skid mounted odorant storage tank.

To set the Tank alarm status, *figure 152*, press and release the **Select** key. The entered value will begin to flash when chosen. Use the **Up Arrow** or **Down Arrow** keys to change the value. When a new value has been chosen, press the **Enter** key to store the new value into memory. The entered value will stop flashing when it has been loaded into memory. Press the **Down Arrow** key to advance to the next parameter.

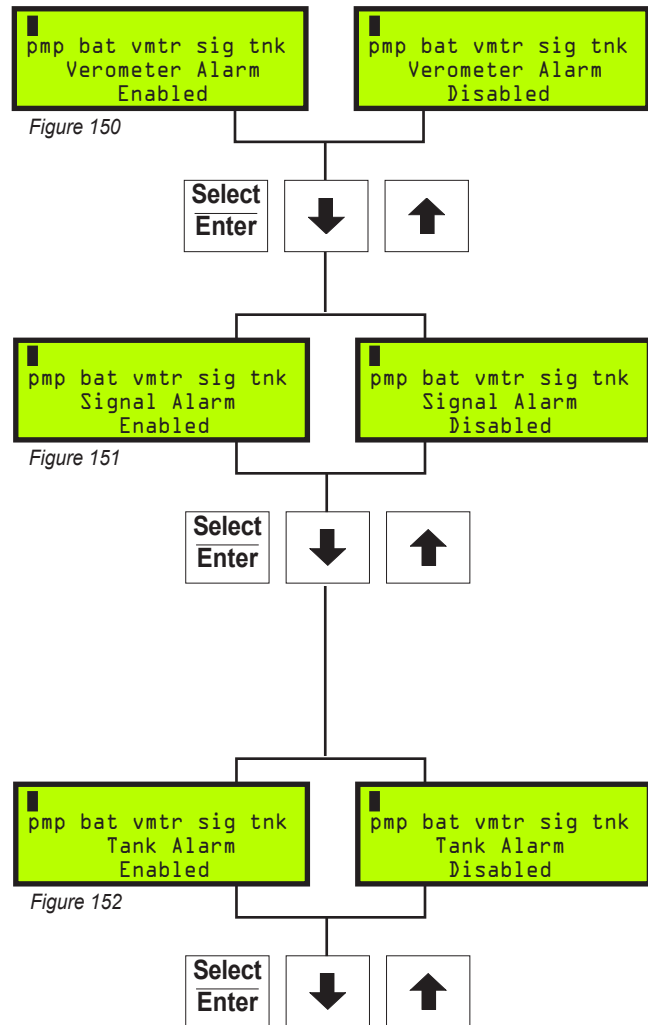

SECTION 9: SETTING & TESTING ALARMS

Testing Alarm Out Status

Alarm outputs that have been enabled will deactivate the alarm output contact located on **TB1**, terminals **#17** and **#18**, refer to the [Wiring Control Document on page 116 in Appendix D: Documents](#). You may test the alarm output in general by choosing the **Alarm SwitchTest** option below, figure 136, or you may choose to **Simulate** specific alarms as illustrated in this section as well.

Choose ***Set** in the main menu, figure 153.

Choose ***Par** – parameters in the Set Selection menu, figure 154.

Choose ***Flow** or ***Time** in the Set Parameters menu, figure 155.

Choose ***Alarm** from the Proportional-to-Time or Flow menus, figure 156.

Choose ***Test** from the Alarm Out Status menu, figure 157.

Choose ***SW** in the Switch / Simulation menu, figures 158.

To activate the Alarm Test Switch, figures 159, press and release the **Select** key. The entered value will flash when it is chosen. Use the **Down Arrow** or **Up Arrow** keys to change the setting. **ON / Relay Open** indicates the alarm relay is in the test mode. **OFF / Relay Closed** indicates the relay is in the normal mode. Press the **Enter** key to load the entry into memory. When the unit is in the **Alarm Test Mode**, a bright red light will flash in the alarm light indicator located just below the **SELECT / ENTER** switch. The display will stop flashing when the entered value is loaded into the memory. Press the **Up Arrow** key to advance to return to the Switch / Simulation menu.

Choose ***Sim** in the Switch / Simulation menu. Any time an alarm is simulated or real, a bright red light will flash in the alarm light indicator located just below the **SELECT / ENTER** switch. Any time a Non-Alarm is simulated or real, a bright green light will flash in the indicator light indicator located just below the **Down Arrow** key.

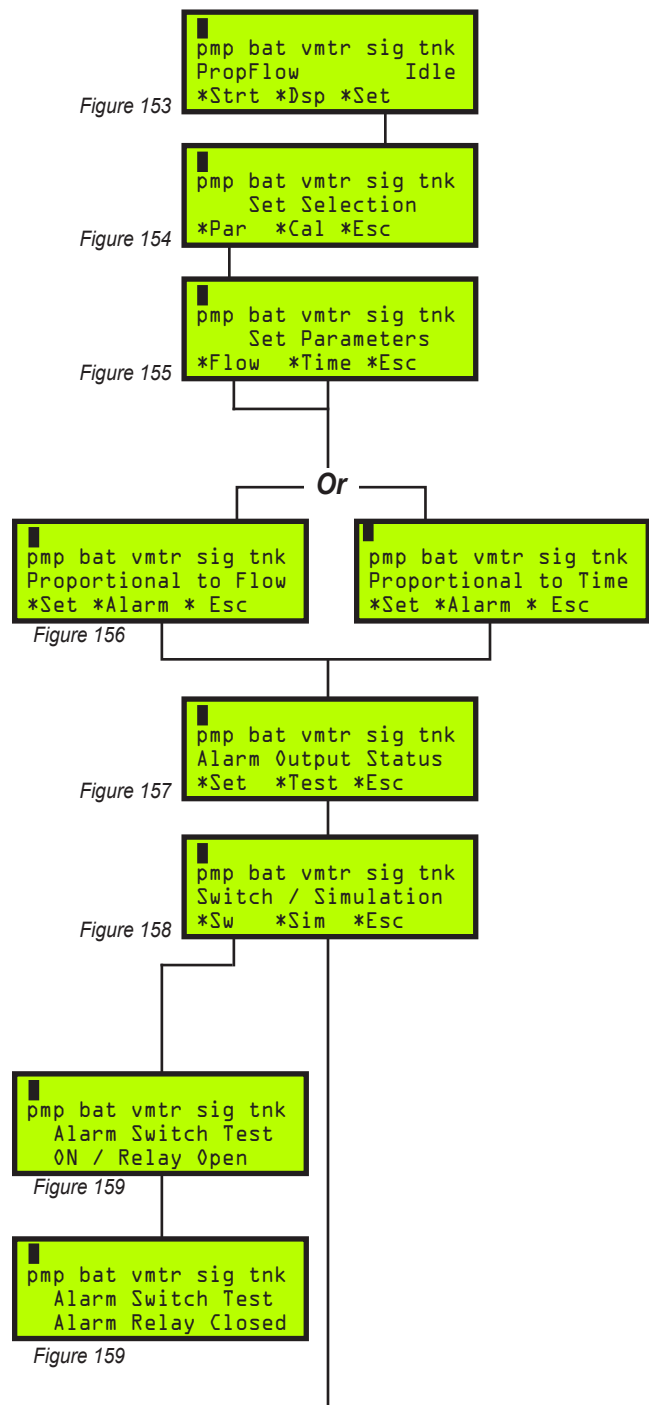

SECTION 9: SETTING & TESTING ALARMS

Testing Alarm Out Status,

Continued

To Simulate the pump alarm status, figures 160, press and release the **Select** key. The **pmp** Alarm indicator in the upper left area of the N-300G display will flash when it is selected. Use the **Down Arrow** or **Up Arrow** keys to simulate which type of pump alarm to activate. This will be shown by the solid block appearing next to **Over Pump**, **Under Pump**, or **Pump Failure** text at the top of the N-300G display, and the **PMP** indicator will be displayed in UPPER CASE letters, and will flash on and off. Press the **Enter** key to return to the simulation selection screen. The display will stop flashing. Press the **Down Arrow** key to advance to the next simulation option.

To Simulate the battery alarm status, figures 161, press and release the **Select** key. The **bat** alarm indicator in the upper left center area of the N-300G display will flash when it is selected. Use the **Down Arrow** or **Up Arrow** keys to simulate a **Low Battery** alarm. This will be shown by the solid block appearing next to **Low Battery** text at the top of the N-300G display, and the **BAT** indicator will now be displayed in UPPER CASE letters, and will flash on and off. Press the **Enter** key to return to the simulation selection screen. The display will stop flashing. Press the **Down Arrow** key to advance to the next simulation option.

To Simulate the verometer alarm status, figures 162, press and release the **Select** key. The **vmtr** alarm indicator in the upper center area of the N-300G display will flash when it is selected. Use the **Down Arrow** or **Up Arrow** keys to simulate which type of Verometer alarm to simulate. This will be shown by the solid block appearing next to **Odor Inlet-Cabl**, **Odor Inlet Lo**, **Odor Inlet Hi**, **XTank-Cable**, **XTank Low**, **XTank High**, **Flvalve-Fail**, **Leakage**, **Slow Fill**, **No Fill**, or **Vmtr-Cable**, text at the top of the N-300G display, and the **VMTR** indicator will now be displayed in UPPER CASE letters, and will flash on and off. Additionally, at this position two Verometer Indicators, **Overfill** and **Fillrate**, that are non-alarms may be simulated in the same manner. They will be indicated at the same location on the N-300G display, but will not have the solid block appearing next to them, and

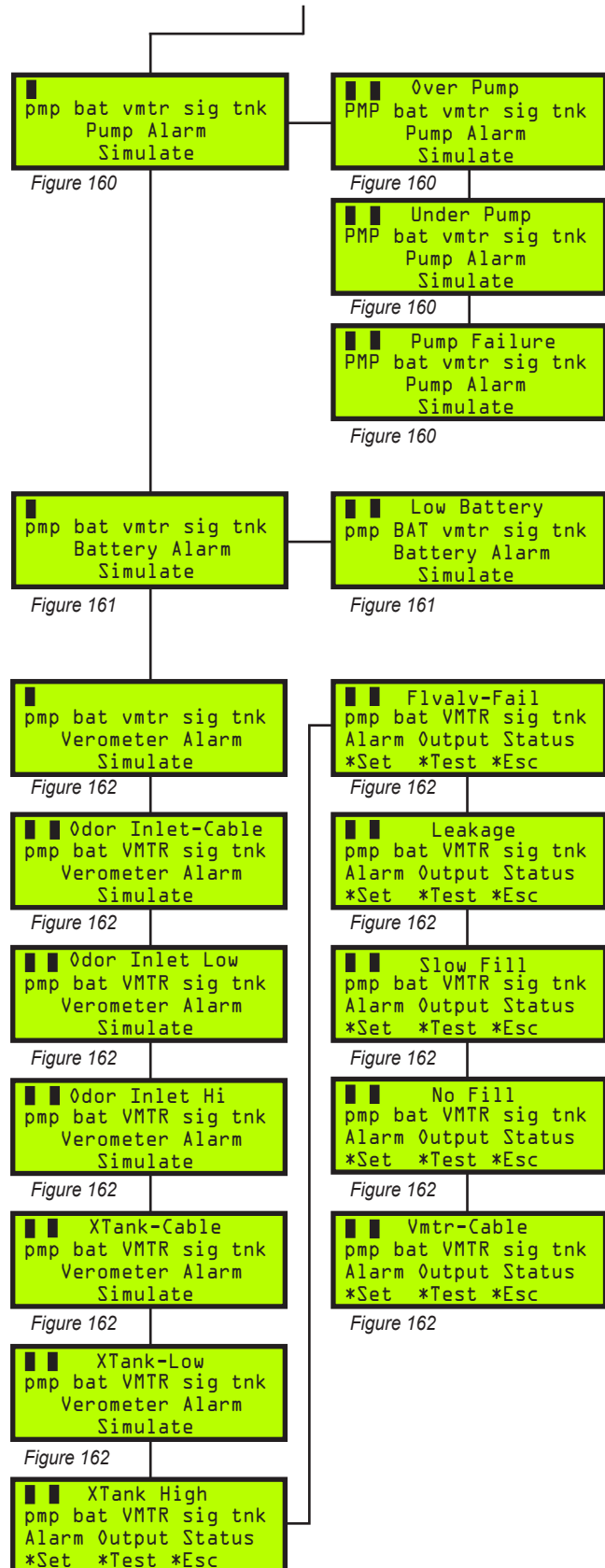

SECTION 9: SETTING & TESTING ALARMS

the **vmtr** indicator will again be in the lower case, but will continue to flash off and on. Press the **Enter** key to return to the simulation selection screen. The display will stop flashing. Press the **Down Arrow** key to advance to the next simulation option.

To Simulate the Signal alarm status, figures 163, press and release the **Select** key. The **sig** alarm indicator in the upper left area of the N-300G display will flash when it is chosen. Use the **Down Arrow** or **Up Arrow** keys to simulate which type of signal alarm to simulate. This will be shown by the solid block appearing next to **Over Flow > 125%**, or **Loss of Signal** text at the top of the N-300G display, and the **SIG** indicator will now be displayed in UPPER CASE letters, and will flash on and off. Additionally at this position three signal Indicators, **OverFlow >110%**, **No Flow**, and **Low Flo Shtoff**, that are non-alarms may be simulated in the same manner. They will be indicated at the same location on the N-300G display, but will not have the solid block appearing next to them, and the **sig** indicator will again be in the lower case, but will continue to flash on and off. Press the **Enter** key to return to the simulation selection screen and the display will stop flashing. Press the **Down Arrow** key to advance to the next simulation option.

To simulate the Tank alarm status, figures 164, press and release the **Select** key. The **tnk** alarm indicator in the upper left area of the N-300G display will flash when it is chosen. Use the **Down Arrow** or **Up Arrow** keys to simulate which type of tank alarm to simulate. This will be shown by the solid block appearing next to **Odor Tank Low**, or **Odor Tank High** text at the top of the N-300G display, and the **TNK** indicator will now be displayed in UPPER CASE letters, and will flash on and off. Press the **Enter** key to return to the simulation selection screen. The display will stop flashing.

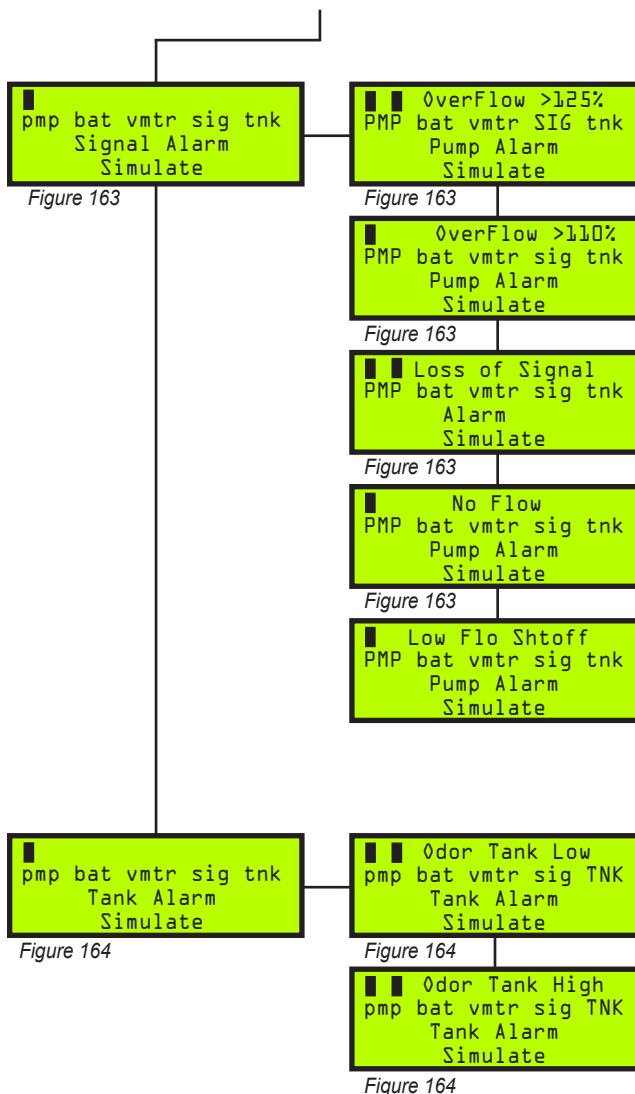

SECTION 9: SETTING & TESTING ALARMS

Setting The Clock

The internal clock in the N-300G should be maintained to reflect the current local time and date. When a system is first placed into service the clock should be set for local time and date. This clock is a 24 hour, military time, clock and therefore the hour of the day will be set between 00:00 and 23:59. It is important that this time and date be correct as data logged will be reflected from this clock setting. If daylight savings time, or other similar hour-shift adjustment, is observed, these changes should be made manually to the clock as they occur. Any change to the clock will be logged in the Sentry4 data file.

Choose ***Set** in the main menu, *figure 165*.

Choose ***Cal** in the set selection menu, *figure 166*.

Choose ***Clk** in the calibration selection menu, *figure 167*.

To set the Clock, figure 168, press and release the **Select** key. First, the numerical value for the **Month** will begin flashing when chosen. Use the **Up Arrow** key to increase the value and the **Down Arrow** key to decrease the value. When a new value has been chosen, press the **Enter** key to store the new **Month** into memory. The entered value will stop flashing when it has been loaded into memory, then the numerical **Day** of the month value will begin to flash. Use the **Up Arrow** key to increase the value and the **Down Arrow** key to decrease the value. When a new **Day** value has been chosen, press the **Enter** key to store the new **Day** into memory and the **Day of The Week** will begin to flash. Use the **Up Arrow** key to increase the value and the **Down Arrow** key to decrease the value. When a new **Day of the Week** has been chosen, press the **Enter** key to store the new **Day of the Week** into memory. Now the **Year** value will begin to flash. Use the **Up Arrow** key to increase the value and the **Down Arrow** key to decrease the value. When a new **Year** has been chosen, press the **Enter** key to store the new **Year** into memory. The last two settings will be for the **Hour** of the day and the minutes after the **Hour**. The **Hour** value will begin to flash. Use the **Up Arrow** key to increase the value

Figure 165

```
pmp bat vmtr sig tnk
PropFlow      Idle
*Strt *Dsp *Set
```

Figure 166

```
pmp bat vmtr sig tnk
Set Selection
*Par  *Cal *Esc
```

Figure 167

```
pmp bat vmtr sig tnk
Calibration Set
*Clk  *Inputs *Esc
```

Figure 168

```
pmp bat vmtr sig tnk
Set Date and Time
12:07 07-12-Thu-2001
```

SECTION 9: SETTING & TESTING ALARMS

and the **Down Arrow** key to decrease the value.

When a new **Hour** has been chosen, press the **Enter** key to store the new **Hour** into memory. Last the **Minutes** after the **Hour** will begin to flash. Use the **Up Arrow** key to increase the value and the **Down Arrow** key to decrease the value. When a new **Minute** value has been chosen, press the **Enter** key to store the new setting into memory. This concludes the Clock Setting Section. Press the **Up Arrow** key three times to return to the main menu.

SECTION 10: MECHANICAL SYSTEM

Overview

The 6300G mechanical system, *figures 169, 170 and 171* are composed of the bulk odorant filter, fill valve, Verometer, 6000 pump, odorant discharge manifold, NJEX gas supply filter, solenoid manifold, pneumatic relay manifold, and the expansion tank. Individual components of the system are shown below and described in the following pages.



Figure 170



Figure 169

Bulk Odorant Filter

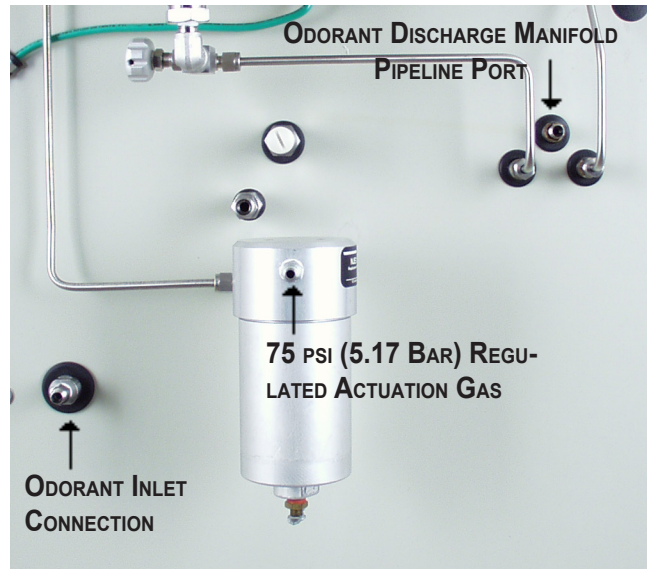

Figure 171

SECTION 10: MECHANICAL SYSTEM

Odorant Inlet Manifold & Bulk Odorant Filter Assembly

The odorant inlet manifold & bulk odorant filter assembly, *figure 172*, is located adjacent to each pump / verometer assembly and performs the following functions:

- Provides the system's odorant supply connection by means of a 1/4" FNPT connection located on the back of the enclosure.
- Provides a pressure gage to show odorant supply pressure from storage tank.
- Provides an odorant supply isolation valve.
- Houses the first of two odorant filter systems within the 6300G System.
- Acts as the odorant return manifold during system purge operations, *refer to Conducting a Forward Purge in Section 12, page 74.*

In the event that the internal filter elements become irtly, a bulk odorant filter repair kit is available.

Fill Valve

The purpose of the fill valve is to control odorant flow into the Verometer, *figure 173*. The fill valve is opened when a pneumatic signal from the solenoid valve manifold depresses the fill valve diaphragm. The valve is closed when the pneumatic signal is removed and the fill valve spring returns the check valve wafer to its seat. The transfer of odorant from the bulk storage tank to the Verometer, when this valve is activated, is dependant on an adequate pressure differential between the bulk storage tank and the Verometer, with the bulk storage tank retaining the higher of the two pressures. These pressures are monitored by two pressure transmitters mounted in the system. One transmitter monitors the incoming pressure from the bulk storage tank, while the other, mounted on the expansion tank, monitors the pressure in the verometer. A differential pressure range of 5 - 10 psi (.345 - .69 Bar) must be present, with the differential not exceeding either end of the range.

The threaded inlet connection to the fill valve allows access to the check valve wafer, return spring, and o-ring seal without disturbing the diaphragm and its seals.

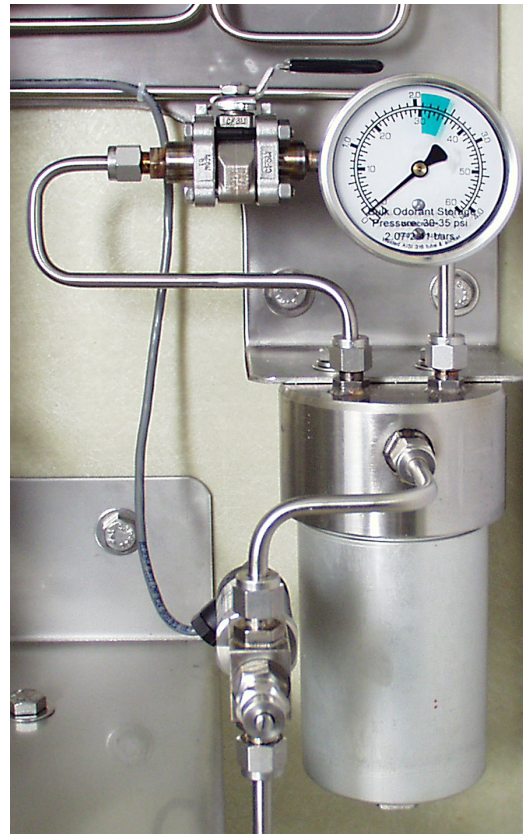

Figure 172



Figure 173

SECTION 10: MECHANICAL SYSTEM

Verometer

The purpose of the Verometer, *figure 174*, is to act as an odorant meter, verifying the amount of injected odorant. The Verometer contains a level monitoring device allowing the N-300G controller to compare the actual amount of odorant injected to the displacement setting of the pump. The N-300G also controls filling the Verometer and activating the Verometer alarm functions based on input from the level monitoring device.

Odorant enters the Verometer from the fill valve. Odorant exits the Verometer by passing through a second filter element on its way to the pump. The filter element is held in place by the filter plug located at the bottom of the Verometer.

The upper portion of the Verometer, above the odorant fluid level, is connected to the expansion tank by stainless steel tubing and the odorant discharge manifold. The purposes for this configuration are:

1. The Verometer / expansion tank connection provides a closed loop system which prevents odorant escape into the atmosphere.
2. As the Verometer is filled, pressure builds within the closed Verometer / expansion tank system. The additional volume provided by the expansion tank prevents the accumulating pressure in the Verometer from equaling the blanket gas pressure in the odorant storage tank. This ensures an uninterrupted flow of odorant from the storage tank to the Verometer.



Figure 174

SECTION 10: MECHANICAL SYSTEM

Model 6000 pump

The NJEX 6000 pump, *figure 175*, is a pneumatically actuated, positive displacement, plunger pump. The 6000 is actuated with compressed air or pipeline gas at a pressure of 30 - 60 psi (2.07 - 4.14 Bar), [refer to Section 2, the System Flow Schematic, illustration 1, on page 6](#). The pump has an adjustable displacement of 0.1cc, or 0.06cc. It achieves proportional-to-flow injection through adjustment of the stroke rate. The 6000 is rated for a maximum stroke rate of 60 strokes per minute.

Each time the pump strokes, the plunger displaces odorant through the discharge check valve. The pump is configured with two sets of plunger seals, segregated from each other with a trapped air space, minimizing the risk of odorant escape into the atmosphere.

The 6000 incorporates a cartridge design in key areas that are most likely to require maintenance. They are: the inlet check valve, the discharge check valve, and the plunger bushing / seal assembly. The cartridge design provides easier maintenance resulting in less down-time.

The gage on the front of the pump reflects any pressure between the two sets of seals in the pump in case of primary seal failure. Normally this gage should be reading "0 psi" and should show no movement. If the gage shows a sudden swing upward in pressure with each stroke of the pump, this is an indication that the pump should be rebuilt due to primary seal damage.



Figure 175

Odorant Discharge Manifold

This manifold is located on the back wall of the mechanical enclosure, just to the left of the verometer and above the pump, *figure 176*. This manifold, located inside the enclosure, has three connections on the bottom of the manifold. The inlet connection in the center of the manifold is the pump discharge, the connection to the right is to the Verometer and the third connection to the left is to the purge bypass loop. These fittings are connected at factory to the appropriate component.

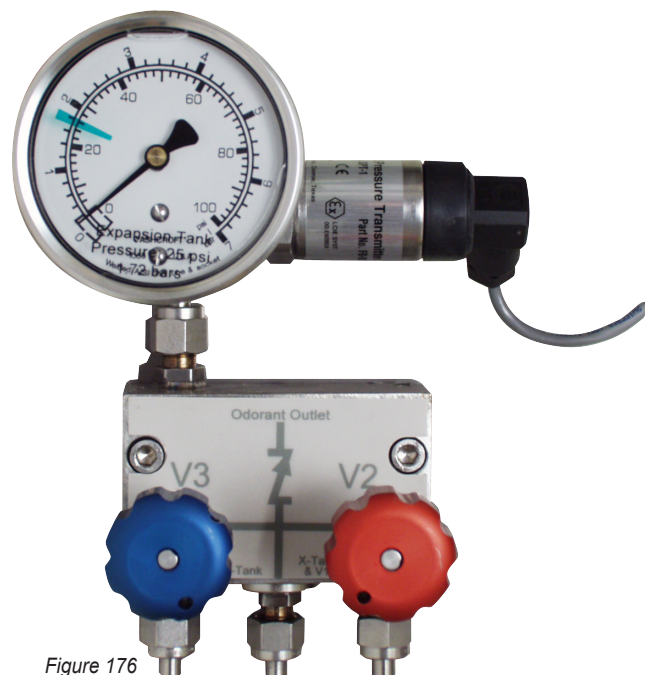

Figure 176

SECTION 10: MECHANICAL SYSTEM

Three outlet ports for the odorant discharge manifold are located on the back of the manifold and extend through the enclosure wall. When facing the back of the enclosure from right to left, these ports are for the expansion tank drain, the pipeline connection, and the expansion tank pressure connection.

Two valves located this manifold control the flow of the odorant blanket gas through the manifold. The valve located on the left, with the blue knob is the purge valve, *refer to Section 12: System Maintenance, page 74-75 Figure 197, valve V3*. The valve, with the red knob, is the bypass valve, *refer to Section 12: System Maintenance, page 74-75 Figure 197, valve V2*. During normal operation, both valves are closed. The bypass valve is opened to empty the 6300G of odorant, *refer to Section 12: System Maintenance, page 74-75 Figure 197* while the purge valve is opened as part of preparing the system for operation *refer to Section 12: System Maintenance, page 80-81, Figure 200*.

An integral wafer check valve is built into the odorant discharge manifold. The wafer is located on top of the plug that is inserted in the bottom of the manifold. This check valve is located in the fluid path between the pump discharge connection and the pipeline connection port.

The gage located on top of this manifold displays the Expansion Tank pressure.

NJEX Gas Filter

A 25 micron coalescent filter is provided with each 6300G. This filter, *figure 177*, is installed on the back outside of the enclosure and should be connected to the regulated (*75 psi / 5.17 Bar*) actuation gas supply provided by the system operator. By conditioning the incoming actuation gas, a clean pneumatic supply will be provided to the solenoid valves. This will ensure a longer operational life for the pneumatic control system. If the actuation gas supply has a high water content and / or a low hydrocarbon dew point, additional filtration and heating of the actuation gas supply may be necessary. Bottled nitrogen can also be used as an alternate gas supply source if gas conditioning is a problem.



Figure 177

SECTION 10: MECHANICAL SYSTEM

Solenoid Valve & Pneumatic Relay Manifold

Two low power solenoid valves are mounted on this manifold, *figure 178*. The solenoid valve, **SV2** located on the left, actuates the fill valve, while the other solenoid valve, **SV1** located on the right, pilots the pump pneumatic relay valve.

One pneumatic relay valve is also mounted on this manifold. It is located just below the solenoid valves and serves to actuate the pump when it receives a pneumatic signal from the pilot relay discusses in the previous paragraph.

Supply and exhaust ports are located on the outside of the manifold to permit operator connections on the back of the system enclosure.

Additionally, there are three control valves located on this manifold, **V4** lower right with a gold knob, **V5** upper center with a green knob, and **V16** lower left with a black knob. Valve **V4** is normally closed, but is opened to charge the expansion tank with gas as required during system start up or purge process. Additionally, valve **V5** is normally closed, but is opened to vent the gas from the expansion tank for maintenance. Finally, **V16** is normally open, and is the supply gas isolation valve.

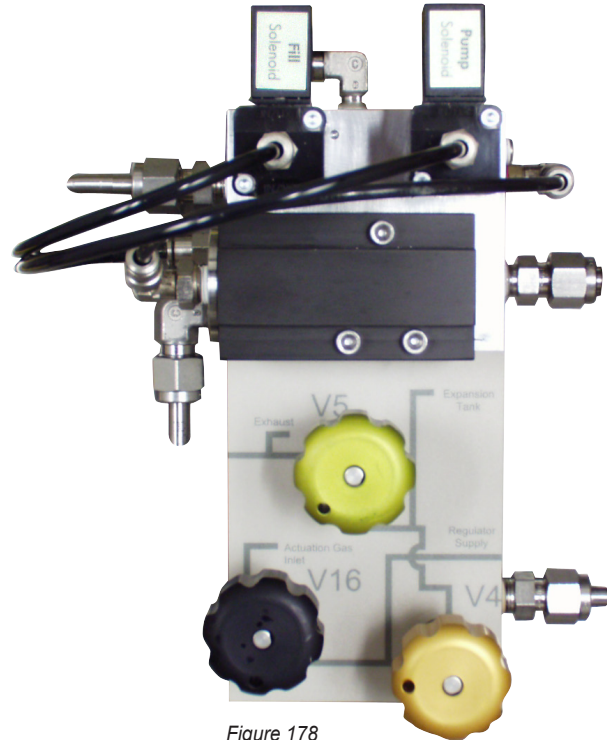

Figure 178

Expansion Tank

The expansion tank, *figure 179*, is mounted on the back of the enclosure and acts as a pressure source and buffer for the Verometer. As the Verometer is filled or emptied, blanket gas flows into or out of the expansion tank as required. Because of the relatively large difference in the volumes of the Verometer and the expansion tank, the fluctuation in operating pressure within this system is minimal.

Mounted on the expansion tank are: a relief valve, preset to 85 psi (5.86 Bar); the low pressure relief valve, and isolation valve, **V6**. The connection on the bottom of the tank, valve **V14**, is used to connect the expansion tank to the bypass loop.

Valve **V14** is normally closed, but can be opened as an optional step in the forward purge process to purge any liquid from the expansion tank that may have accumulated, and place it back into the bulk storage tank.



Figure 179

SECTION 11: SYSTEM OPERATION

Setting System Pressures and Valves

Before attempting to start the system, check for proper valve positions as indicated on the normal operation schematic on the enclosure door, and set all pressures accordingly, *figure 180*.

1. Adjust supply gas regulator to provide 75 psi (5.17 Bar) to the NJEX gas filter.
2. Temporarily open valve **V4** to fill the expansion tank to a pressure of 25 psi (1.72 Bar) then close **V4**.
3. Verify low pressure relief operation and adjust as necessary to maintain a specific pressure of 25psi (1.72 Bar).
4. Adjust the pump actuation regulator to the required pressure to inject into pipeline pressure as indicated on the normal operation schematic located on the enclosure door.
5. Adjust the blanket gas regulator for the bulk storage tank.
6. Check entire system for gas leaks and verify that the set pressures remain constant.

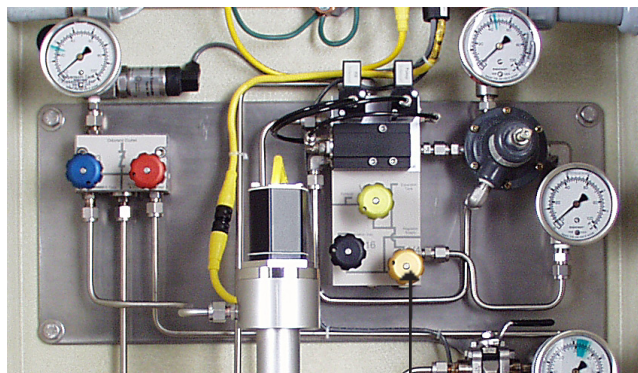

Figure 180

Valve V4

Low Pressure Relief Adjustment

The overflow protector, *figure 181*, incorporates a low pressure relief in the cap assembly for the purpose of maintaining the maximum expansion tank pressure at 25 psi (1.72 Bar).

To test and adjust follow these steps:

1. With valve **V6** open, slowly open valve **V4** until gas begins discharging at exhaust port of the overflow protector.
2. Close valve **V4** and see where pressure stabilizes which should be 25 psi (1.72 Bar).
3. If adjustment is needed:
 - a) First, loosen adjustment lock nut, located at the top of the overflow protector. To increase pressure in the tank, turn the adjustment screw in, or to the right. To lower pressure tank, turn the adjustment screw out, or to the left.
 - b) Tighten the lock nut.
 - c) Repeat until the desired pressure of 25 psi (1.72 Bar) is obtained as described in step 2 above.

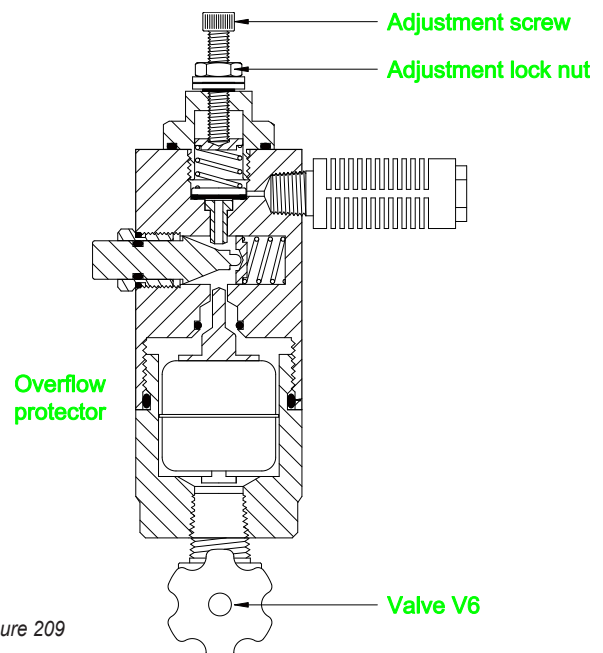

Figure 209

SECTION 11: SYSTEM OPERATION

Starting The System

Turn the main power switch, located inside the N-300G enclosure, *figure 182*. To access the switch, pull out and upward on the lever located on the right side of the N-300G enclosure. On the circuit board inside the N-300G enclosure, the On / Off switch is located on the lower right side. Flip the switch up to turn the main power on.

Once the NJEX System is powered-up, the following menus will appear in the LCD screen on the N-300G controller, follow instructions provided.

- Observe the LCD screen to ensure the **Serial Number** and **Model Type** shown match the **Serial Number** and **Model Type** on the inside of the enclosure door, *figures 183*.
- Verify **Verometer Calibration Number** matches the Verometer tag number located at the top of the Verometer assembly, *figure 184*.
- For future reference, record the **Version x.xx** number, *figure 185*, on the *For the Record form, located in the Appendix C: Response Forms, on page 113*.

IMPORTANT:

If the serial number, model type or the verometer tag number does not match the corresponding numbers featured on the N-300G controller consult the factory before proceeding further.

Press the **Down Arrow** key four times to scroll the display menu to the **Meter Level** display, *figure 186*.

Press the **Select / Enter** key to choose the ***Fill** command, *figure 186*. The meter level display will show the Verometer level as the meter reservoir fills to 100%, *figure 187*.

Note: *initial filling may take 2-3 minutes. Adjust the fill rate at the fill rate control valve V9. After initial fill, a fill cycle should take 45 seconds to 1 minute.*

Open valve **V3** and use the **Test** key to stroke the pump a minimum of 20 times. Additional strokes may be necessary if the pump displacement is restricted with a pump stroke spacer.

A decrease in the Verometer Level should be ob-



Figure 182

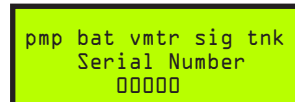

Figure 183



Figure 183

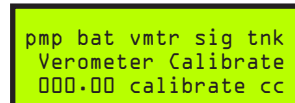

Figure 184

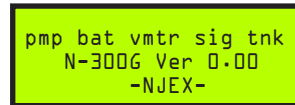

Figure 185

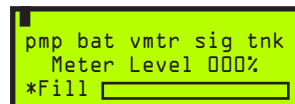
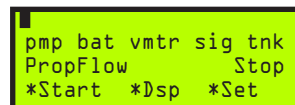

Figure 186

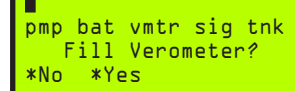

Figure 187

SECTION 11: SYSTEM OPERATION

served. Close valve **V3** and press the **Up Arrow** key four times to return to the main menu.

Choose the ***Start** entry from the main menu, *figures 188*. The meter level display will indicate the Verometer level as the verometer refills to 100%.

Next, choose the mode of operation in the Proportional-to-Flow or Time display, for either the ***Flow** or ***Time** entry, *figure 189*.

Note: the ***Time** option will not appear if disabled at the time interval setting, refer to [Section 6: Programming for Proportional-to-Time Operation, page 33, Time Interval between strokes of the pump....](#)

To start the pump press the ***Yes** entry, *figure 190*.

If the calculated time / stroke is less than the minimum, the **Time / Stroke Calculated Exceeds Minimum** display will appear, and the system will not start, *figure 191*. Refer to [Section 5, page 25, Proportion-to-Flow Mode, Setting Operator Input Parameters, to set the correct parameters for the NJEX 6300G System.](#)

The **Prop Flow / Time x:xx:xx** display that follows, *figure 192*, provides a count down to the next pump stroke.

To Stop The System

To stop the pump, in the **Prop Flow/Time x:xx:xx** display, *figure 192*, press the ***Stop** entry. The following **Stop Pump** display, *figure 193*, then provides the option to press the ***No** or ***Yes** entry. Press the ***Yes** entry to stop the pump.

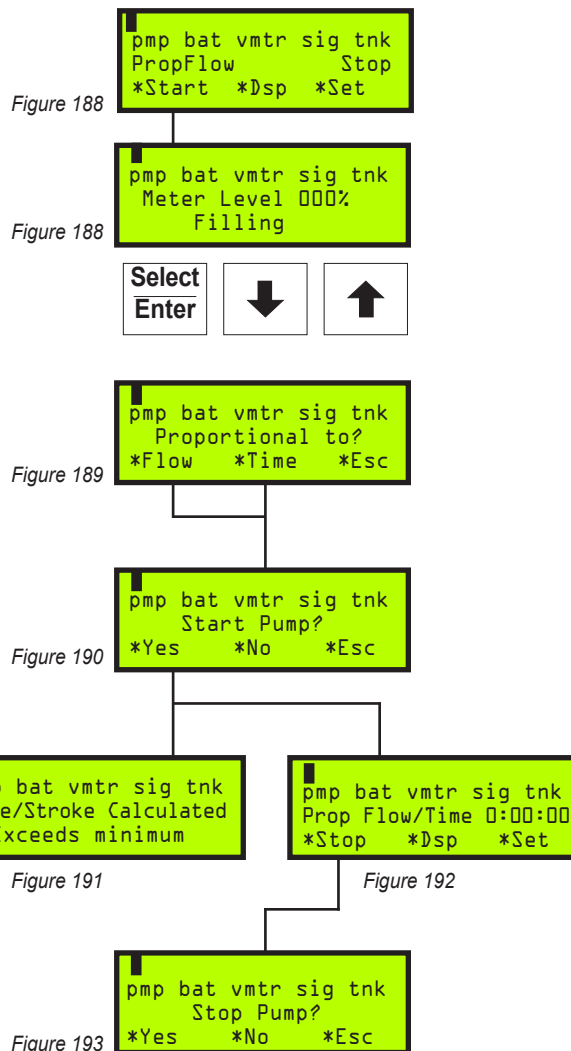

SECTION 12: SYSTEM MAINTENANCE

Preventative Maintenance Schedule

A preventative maintenance program serves to anticipate maintenance issues prior to waiting until the system requires service. Like changing the oil & filters in an automobile, by choosing to service the various parts and operation in the NJEX System at regular intervals, the technician can perform the maintenance service when desired, rather than when required, such as in the middle of night.

The key is to perform maintenance before it is required. The preventative maintenance schedule implemented should consider the application of the odorizer. Many of these considerations include: the weather environment; the condition of, the actuation gas, the odorant and the odorant bulk storage tank, and the pump stroke frequency. All of these issues must be considered when establishing a preventative maintenance schedule.

Recommended Maintenance Schedule Weekly Inspection

1. Verify gas pressures
2. Check for gas and odorant leaks
3. View the N-300G Controller for alarm indications

Semi-Annual Inspection

1. Inspect overflow protector and service as needed
2. Inspect tube fittings and valve packings for leaks.

Annual Inspection

1. Change filters
2. Rebuild pump
3. Replace solenoids
4. Test the relief valve and service, as needed
5. Test regulators and service, as needed
6. Condition the odorant, as needed.
7. Test the NJEX System performance

Bi-Annual Inspection

1. Perform the annual inspection listed above
2. Replace the battery
3. Replace pneumatic relay valve

Recommended Spare Parts List

Part #	Description	Recommended Quantity
A4-0010	3-way solenoid valve	2
A3-0290	Pneumatic relay valve	1
C4-0133	NJEX gas filter replacement filter element	1
D3-0103	Bulk odorant filter element replacement kit	1
D3-0140	Model 6000B pump seal replacement kit	1
D3-0126	Verometer filter element kit	1

SECTION 12: SYSTEM MAINTENANCE

Overflow Protector Assembly Inspection

The overflow protector assembly should be inspected as follows on each NJEX System in operation, *figure 194*:

1. Isolate the protector by closing valve **V6** located just below the overflow protector on the expansion tank.
2. Slowly remove the protector upper housing, **item A**, by unscrewing it from the protector lower valve body, **item B**.
3. Inspect the dart and o-ring seal, **item C**, located in the upper body. It should not be sticky or unusually shaped. If any distortion to this o-ring is found it should be replaced immediately. A normal fitting o-ring will exhibit a slight interference between the dart and the o-ring when in contact with each other. This contact is what causes the seal when necessary.
4. Inspect the cap to body o-ring, **item D**, and lubricate or replace as necessary.
5. Inspect the reset push button. When pushed in, the button should depress, then spring back freely. If any sticking occurs, the o-ring, **item E**, should be lubricated.
6. To reinstall the protector upper housing, first assure that the dart is fully inserted into the housing contacting the o-ring seal. Second, install the upper housing onto the lower body, assuring that the cap comes to a full seated position against the protector lower body.
7. Depress the **Reset** button to reset the dart.
8. Slowly open valve **V6** below the protector.
9. The **Reset** button on the side of the overflow protector is utilized to test the function of the low pressure relief and to reset the overflow dart. Pressing this button will over-ride the low pressure relief and the overflow protection dart.

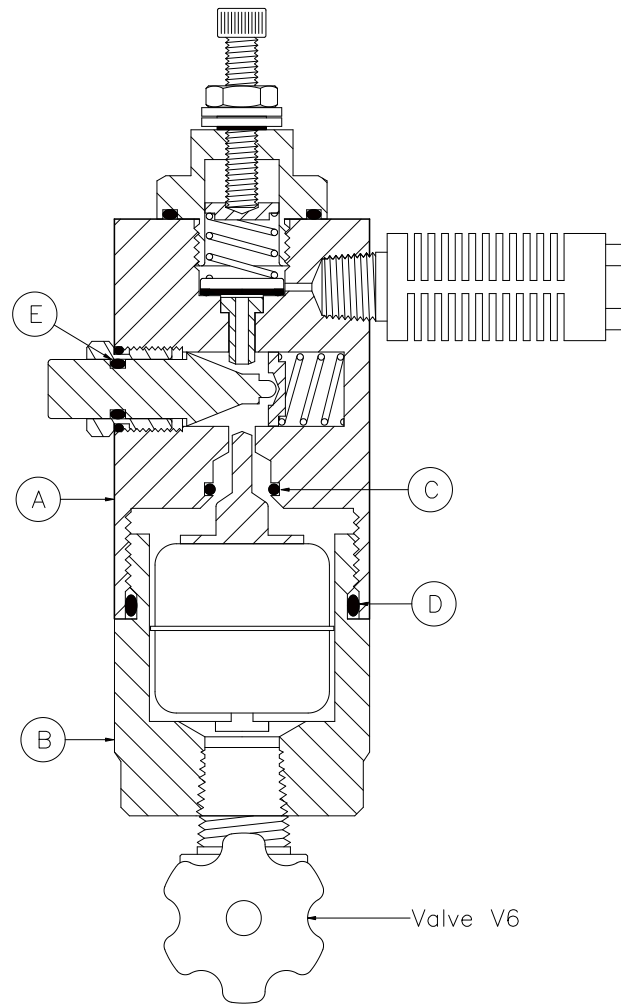

Figure 225

SECTION 12: SYSTEM MAINTENANCE

Note: This should be inspected by the maintenance technician on a regular basis. Caution should always be used as odorant may escape if the expansion tank has been allowed to filled with odorant. Odorant fill of the expansion tank is not a normal or recommended operating condition.

Low Pressure Relief Adjustment

The overflow protector incorporates a low pressure relief in the cap assembly for the purpose of maintaining the maximum expansion tank pressure at 25 psi (1.72 Bar).

To test and adjust follow these steps:

1. With valve **V6** open, *figure 196*, slowly open valve **V4**, *figure 195*, until gas begins discharging at exhaust port.
2. Close valve **V4** and see where pressure stabilizes which should be 25 psi (1.72 Bar).
3. If adjustment is needed:
 - a) First, loosen adjustment lock nut, located on top of the overflow protector. To increase pressure in the tank, turn the adjustment screw in, or to the right. To lower pressure tank, turn the adjustment screw out, or to the left.
 - b) Tighten lock nut.
 - c) Repeat until the desired pressure of 25 psi (1.72 Bar) is obtained as described in in step 2 above.

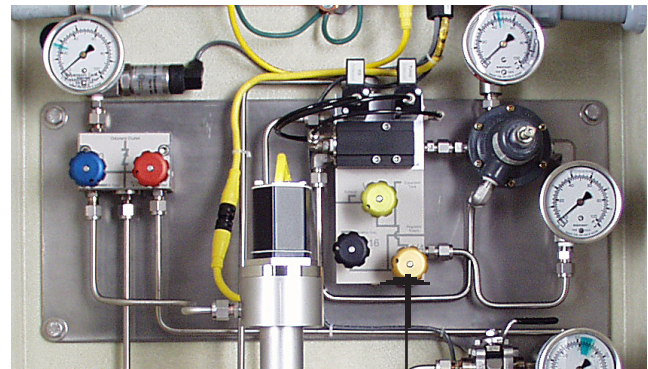

Figure 195

Valve V4

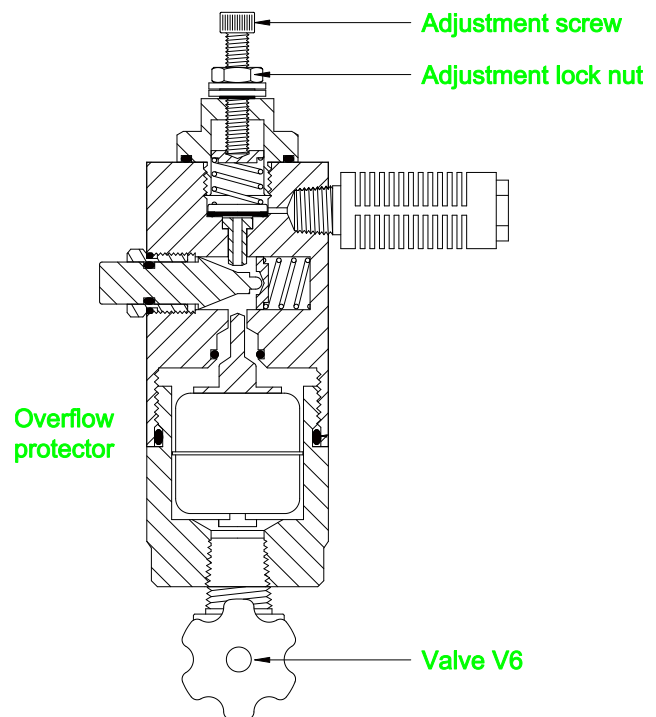

Figure 227

SECTION 12: SYSTEM MAINTENANCE

Conducting a Forward Purge

Figure 197

1. Place the NJEX System in **Standby** mode by pressing the **Standby** key on the N-300 controller.
2. Close valves **V8** and **V6**
3. Open valve **V4** until pressure reaches 50-60 psi (3.4-4 Bar) in the expansion tank, then close valve **V4**.
4. Scroll to the **Meter Level** display on the N-300 controller
5. Open valve **V2** until:
 - a) **Empty** is indicated in the **Meter Level** displayAnd
 - b) Gas bubbling in the bulk odorant storage tank becomes audible.
6. Close valve **V17**
7. Proceed to the Venting Pressure Gas procedure on [page 76](#).

SECTION 12: SYSTEM MAINTENANCE

Figure 197

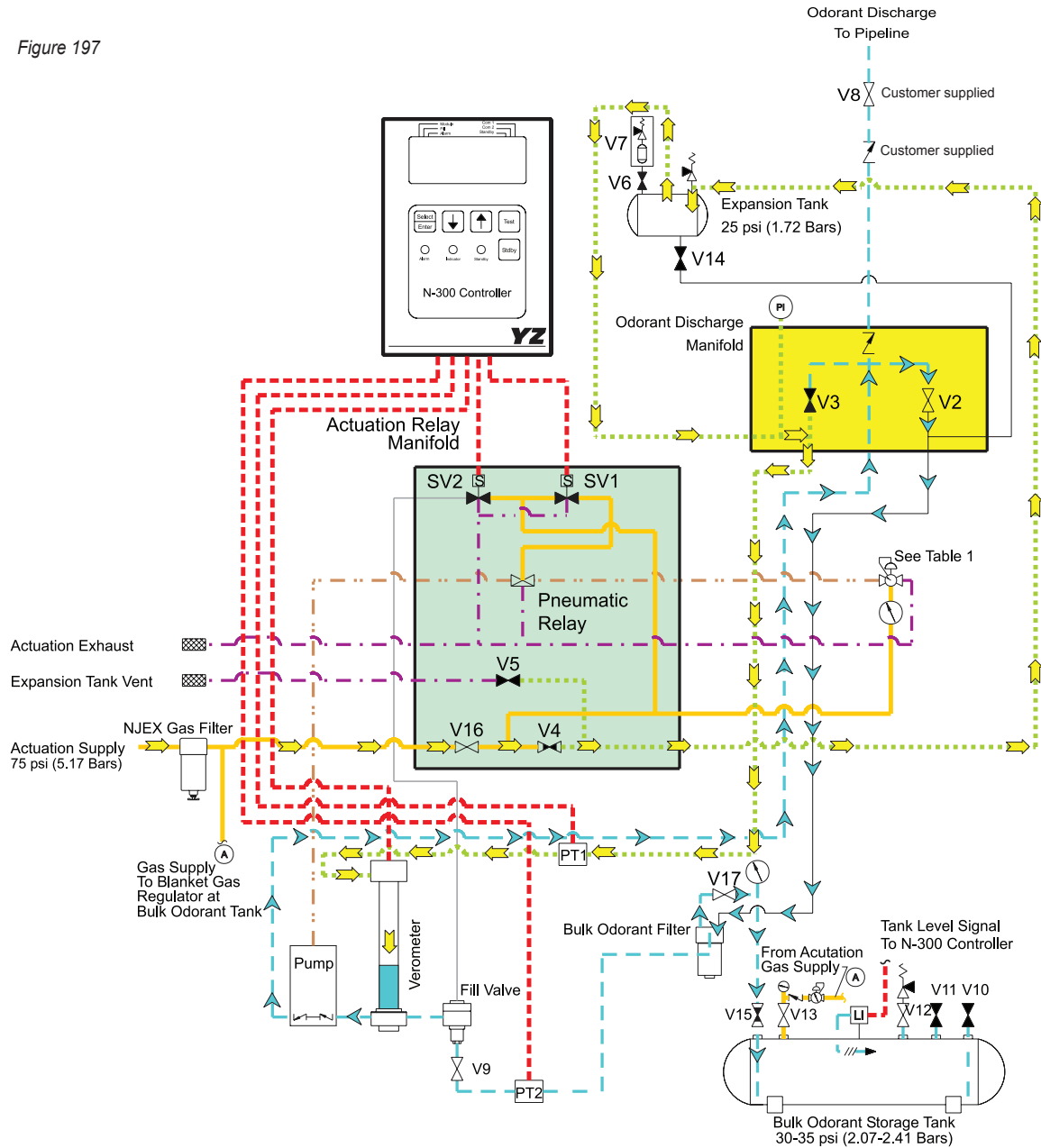

Table 1	
6300	
Pipeline Pressure	Actuation Pressure
100 - 200 PSI (6.89 - 13.8 Bar)	30 PSI (2.07 Bar)
200 - 500 PSI (13.89 - 34.5 Bar)	40 PSI (2.76 Bar)
500 - 900 PSI (34.5 - 62.1 Bar)	50 PSI (3.45 Bar)
900 - 1400 PSI (62.1 - 96.5 Bar)	60 PSI (4.14 Bar)

IMPORTANT: Read And Follow Steps 1-4 BEFORE Proceeding

- Place the controller in the "standby" mode.
- Close all valves marked "X".
- Open all valves marked "O".
- Place controller in the proper mode of operation as needed.

X - Open to build pressure to 60 psi (4.14 Bars) then close valve
 * - Adjust as needed

	V2	V3	V4	V5	V6	V8	V9	V10	V11	V12	V13	V14	V15	V16	V17
Normal Operation	X	X	X	X	O	O	*	X	X	O	O	X	O	O	O
System Purge	O	X	X	X	X	X	*	X	X	O	O	X	O	O	O
System Vent	O	O	O	O	X	X	*	X	O	O	O	X	O	O	X
Leak Test	O	O	O	X	X	X	*	X	X	O	O	X	O	O	X
Prime Pump	X	O	X	X	O	X	*	X	X	O	O	X	O	O	O

LEGEND

- | | | | | |
|---|---|--|--|--|
| <ul style="list-style-type: none"> Normally Closed Valve Normally Open Valve Pneumatic Relay Check Valve Float Valve Pressure Gauge Electronic Level Transmitter Solenoid Valve Pressure Regulator w/Gauge Pressure Relief Valve Pressure Transmitter | <ul style="list-style-type: none"> Liquid Odorant - Normal Operation Purge/Drain Line Expansion Line Intrinsically Safe Electrical Line Exhaust/Vent Line Actuation Line 75 psi (520 Kpa) Fill Valve Actuation Line Pump Actuation Line Odorant Actuation Gas | <ul style="list-style-type: none"> V2 Purge Valve (Red Knob) V3 Prime Valve (Blue Knob) V4 Expansion Tank Pressure Supply Valve (Gold Knob) V5 Expansion Tank Vent Valve (Green Knob) V6 Expansion Tank Overflow Preventor Isolation Valve V7 Expansion Tank Overflow Preventor Isolation Valve V8 Isolation Valve V9 Fill Rate Control Valve V10 Odorant Storage Tank Fill Valve | <ul style="list-style-type: none"> V11 Odorant Storage Tank Vapor Return Valve V12 Odorant Storage Tank Relief Valve Isolation Valve V13 Odorant Storage Tank Blanket Gas Isolation Valve V14 Expansion Tank Drain Valve V15 Odorant Storage Tank Supply Isolation Valve V16 Gas Supply Isolation Valve (Black Knob) V17 System Odorant Supply Isolation Valve SV1 Odorant Storage Tank Solenoid Valve | <ul style="list-style-type: none"> SV2 Fill Valve Solenoid Valve PT1 Expansion Tank Pressure Transmitter PT2 Odorant Inlet Pressure Transmitter |
|---|---|--|--|--|

SECTION 12: SYSTEM MAINTENANCE

Venting Pressure Gas

Figure 198

Refer to the Venting Pressure Gas Operational Schematic figure 198, on page 77.

1. Open valve **V3**

CAUTION:

Vented gas will have a strong odorant smell.

2. Connect a **Gas Flare Device** or **Odorant Filter / Scrubber** as required, to the **Expansion Tank Vent** connection on the back of the NJEX System enclosure
3. Slowly open valve **V5** and allow all pressure to vent from the NJEX System
4. Perform required maintenance, then proceed to the Fill Procedure on [page 78](#).

SECTION 12: SYSTEM MAINTENANCE

Figure 198

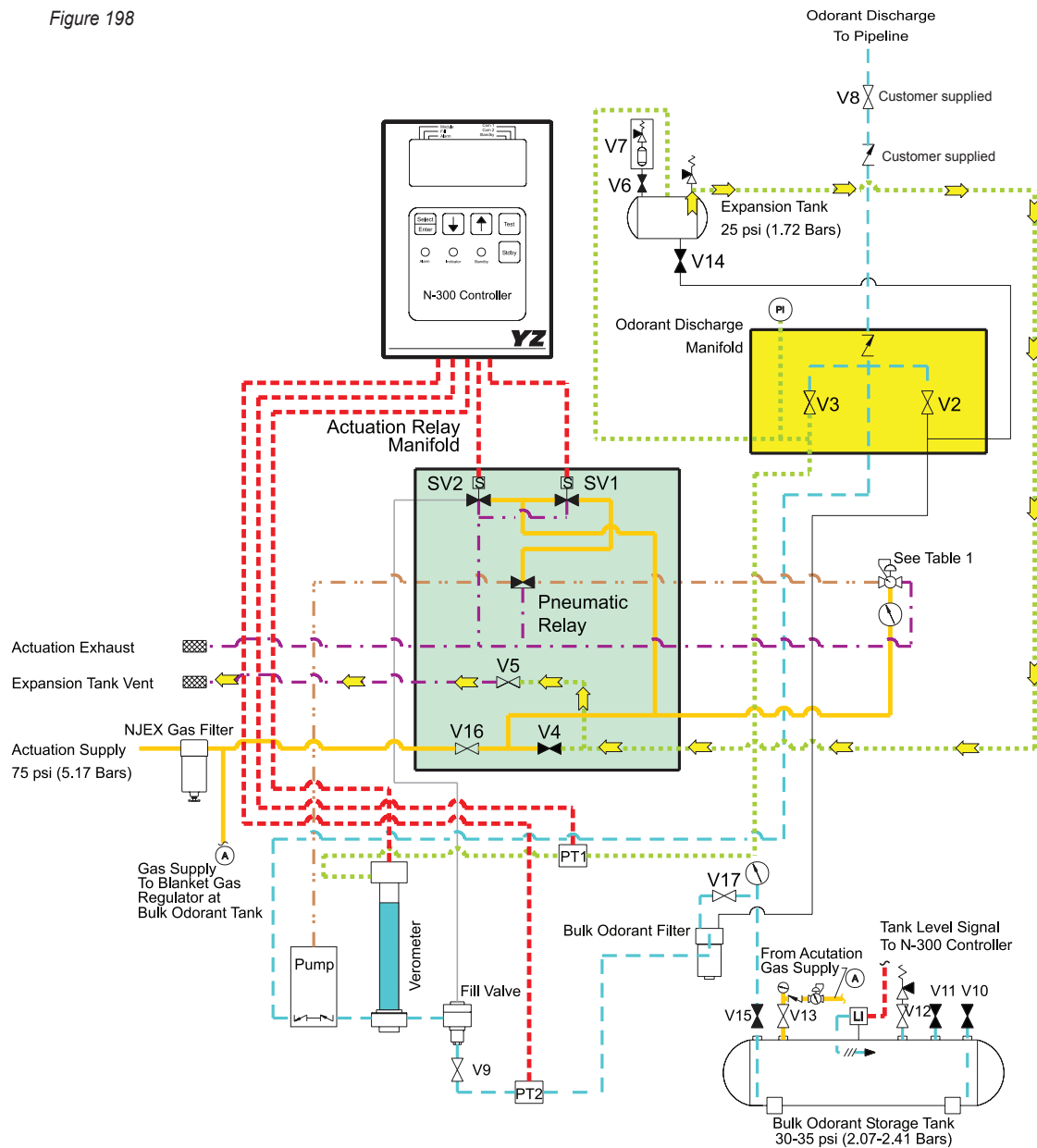

Table 1	
6300	
Pipeline Pressure	Actuation Pressure
100 - 200 PSI (6.89 - 13.8 Bar)	30 PSI (2.07 Bar)
200 - 500 PSI (13.89 - 34.5 Bar)	40 PSI (2.76 Bar)
500 - 900 PSI (34.5 - 62.1 Bar)	50 PSI (3.45 Bar)
900 - 1400 PSI (62.1 - 96.5 Bar)	60 PSI (4.14 Bar)

IMPORTANT: Read And Follow Steps 1-4 BEFORE Proceeding

- Place the controller in the "standby" mode.
- Close all valves marked "X".
- Open all valves marked "O".
- Place controller in the proper mode of operation as needed.

■ Open to build pressure to 60 psi (4.14 Bars) then close valve
 * Adjust as needed

	V2	V3	V4	V5	V6	V8	V9	V10	V11	V12	V13	V14	V15	V16	V17
Normal Operation	X	X	X	X	O	O	*	X	X	O	O	X	O	O	O
System Purge	O	X	■	X	X	X	*	X	X	O	O	X	O	O	O
System Vent	O	O	X	O	X	X	*	X	X	O	O	X	O	O	X
Leak Test	O	O	O	X	X	X	*	X	X	O	O	X	O	O	X
Prime Pump	X	O	X	X	O	X	*	X	X	O	O	X	O	O	O

LEGEND

<ul style="list-style-type: none"> ☒ Normally Closed Valve ☒ Normally Open Valve ☒ Pneumatic Relay ☒ Check Valve ☒ Float Valve ☒ Pressure Gauge ☒ Electronic Level Transmitter ☒ Solenoid Valve ☒ Pressure Regulator w/Gauge ☒ Pressure Relief Valve ☒ Pressure Transmitter 	<ul style="list-style-type: none"> — Liquid Odorant - Normal Operation — Purge/Drain Line — Expansion Line — Intrinsic Safe Electrical Line — Exhaust/Vent Line — Actuation Line 75 psi (520 Kpa) — Fill Valve Actuation Line — Pump Actuation Line — Odorant — Actuation Gas 	<ul style="list-style-type: none"> V2 Purge Valve (Red Knob) V3 Prime Valve (Blue Knob) V4 Expansion Tank Pressure Supply Valve (Gold Knob) V5 Expansion Tank Vent Valve (Green Knob) V6 Expansion Tank Overflow Preventor Isolation Valve V7 Expansion Tank Overflow Preventor V8 Isolation Valve V9 Fill Rate Control Valve V10 Odorant Storage Tank Fill Valve 	<ul style="list-style-type: none"> V11 Odorant Storage Tank Vapor Return Valve V12 Odorant Storage Tank Relief Valve Isolation Valve V13 Odorant Storage Tank Blanket Gas Isolation Valve V14 Expansion Tank Drain Valve V15 Odorant Storage Tank Supply Isolation Valve V16 Gas Supply Isolation Valve (Black Knob) V17 System Odorant Supply Isolation Valve 	<ul style="list-style-type: none"> SV2 Fill Valve Solenoid Valve PT1 Expansion Tank Pressure Transmitter PT2 Odorant Inlet Pressure Transmitter
--	---	--	---	--

SECTION 12: SYSTEM MAINTENANCE

Filling the Verometer

Figure 199

Refer to the Filling the Verometer Operational Schematic figure 199, on page 79.

1. Close valve **V2**, **V3**, and **V5**
2. Open valve **V4** until gauge reads 25 psi (1.72 Bar) and then close **V4**.
3. Open valve **V17**
4. Place the NJEX System in **Standby** mode by pressing the **Standby** key on the front of the N-300 controller. The Standby LED indicator will begin to flash on and off.
5. Scroll to the **Meter Level** display on the N-300 controller and select ***Fill**.
6. Press **Standby** key to reactivate normal operation. The Verometer will begin to fill.
7. Proceed to the Prime & Start procedure of [page 80](#).

SECTION 12: SYSTEM MAINTENANCE

Figure 199

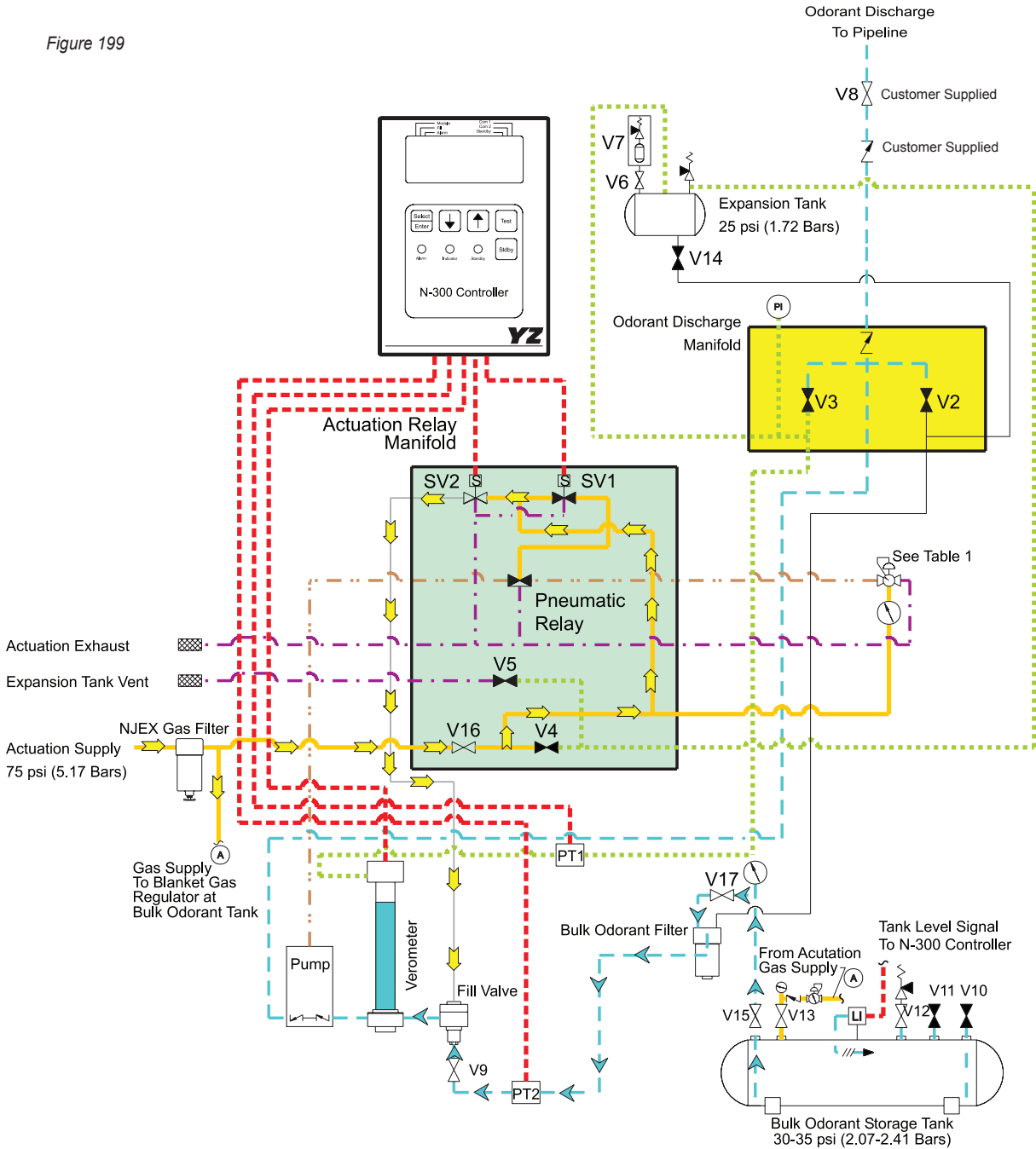

6300	
Pipeline Pressure	Actuation Pressure
100 - 200 PSI (6.89 - 13.8 Bar)	30 PSI (2.07 Bar)
200 - 500 PSI (13.89 - 34.5 Bar)	40 PSI (2.76 Bar)
500 - 900 PSI (34.5 - 62.1 Bar)	50 PSI (3.45 Bar)
900 - 1400 PSI (62.1 - 96.5 Bar)	60 PSI (4.14 Bar)

IMPORTANT: Read And Follow Steps 1-4 BEFORE Proceeding

- Place the controller in the "standby" mode.
- Close all valves marked "X".
- Open all valves marked "O".
- Place controller in the proper mode of operation as needed.

■ - Open to build pressure to 60 psi (4.14 Bars) then close valve
* - Adjust as needed

	V2	V3	V4	V5	V6	V7	V8	V9	V10	V11	V12	V13	V14	V15	V16	V17
Normal Operation	X	X	X	X	O	O	*	X	X	O	O	X	O	X	O	O
System Purge	O	X	■	X	X	X	*	X	X	O	O	X	O	X	O	O
System Vent	O	O	X	O	X	X	*	X	X	O	O	X	O	X	O	X
Leak Test	O	O	O	X	X	X	*	X	X	O	O	X	O	X	O	X
Prime Pump	X	O	X	X	O	X	*	X	X	O	O	X	O	O	O	O

LEGEND

- ☒ Normally Closed Valve

☒ Normally Open Valve

☒ Pneumatic Relay

☒ Check Valve

☒ Float Valve

☒ Pressure Gauge

☒ Electronic Level Transmitter
- Liquid Odorant - Normal Operation

— Purge/Drain Line

— Expansion Line

— Intrinsically Safe Electrical Line

— Exhaust/Vent Line

— Actuation Line 75 psi (520 Kpa)

— Fill Valve Actuation Line
- V2 Purge Valve (Red Knob)

V3 Prime Valve (Blue Knob)

V4 Expansion Tank Pressure Supply Valve (Gold Knob)

V5 Expansion Tank Vent Valve (Green Knob)

V6 Expansion Tank Overflow Preventor Isolation Valve

V7 Expansion Tank

V11 Odorant Storage Tank Vapor Return Valve

V12 Odorant Storage Tank Relief Valve Isolation Valve

V13 Odorant Storage Tank Blanket Gas Isolation Valve

V14 Expansion Tank Drain Valve

V15 Odorant Storage Tank Isolation Valve

SV2 Fill Valve Solenoid Valve

PT1 Expansion Tank Pressure Transmitter

PT2 Odorant Inlet Pressure Transmitter

SECTION 12: SYSTEM MAINTENANCE

Priming & Starting the NJEX System

Refer to the Priming and Starting the NJEX System Operational Schematic figure 200, on page 80.

1. Place unit in the **Standby** mode by pressing the Standby key located on the front of the N-300 controller. The **Standby** LED will begin the flash on and off.
2. Verify that valve **V8** is closed.
3. Open valve **V3**
4. Press the Standby key one more time to remove the system from the **Standby** mode. The **Standby** LED should stop flashing on and off, and remain off.
5. Manually stroke the pump 15-20 times.
6. Close valve **V3**
7. Open valve **V8**
8. Select ***Start** from the main N-300 controller menu, and follow N-300 instructions to start the system.

SECTION 12: SYSTEM MAINTENANCE

Figure 200

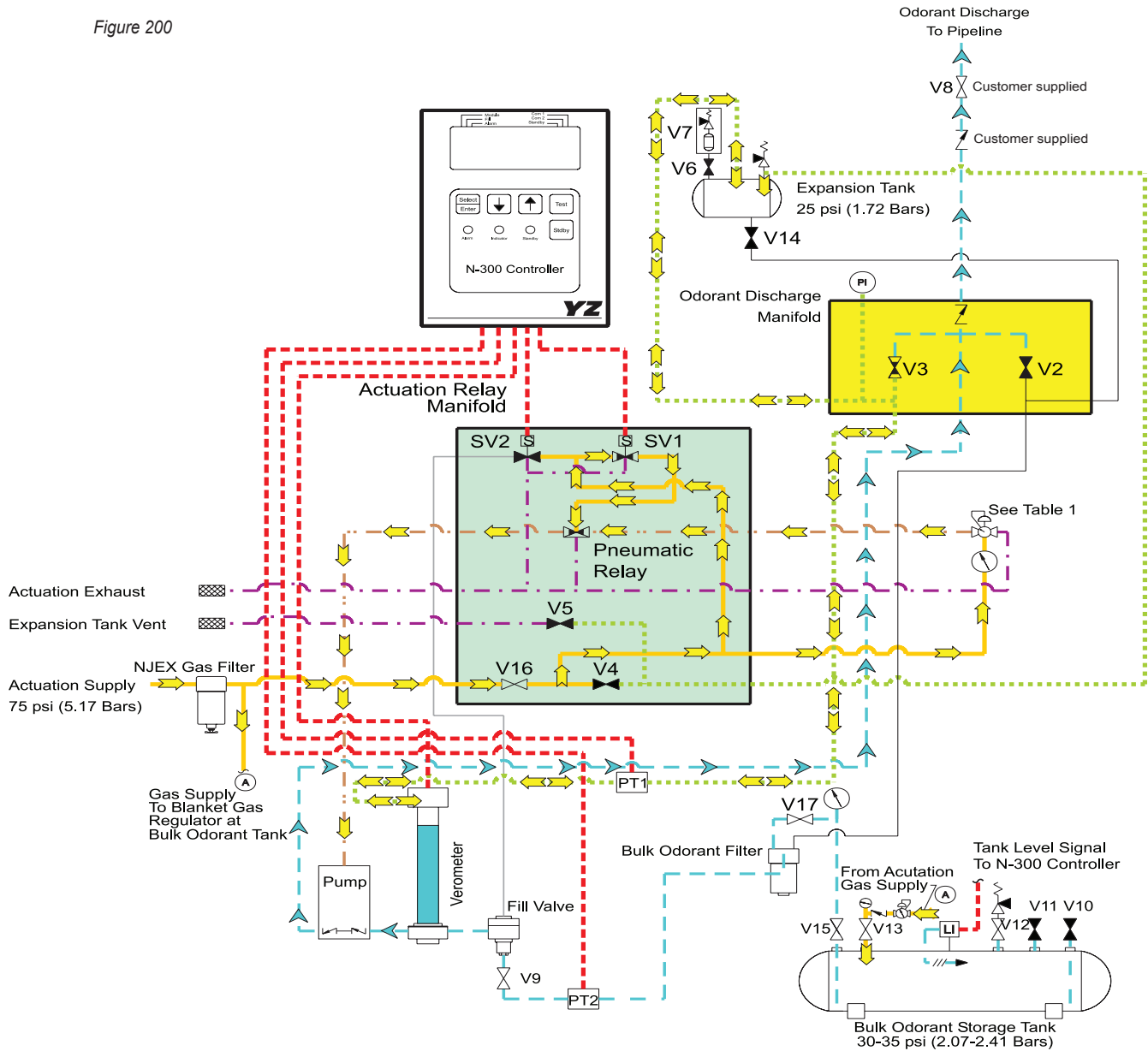

Table 1	
6300	
Pipeline Pressure	Actuation Pressure
100 - 200 PSI (6.89 - 13.8 Bar)	30 PSI (2.07 Bar)
200 - 500 PSI (13.89 - 34.5 Bar)	40 PSI (2.76 Bar)
500 - 900 PSI (34.5 - 62.1 Bar)	50 PSI (3.45 Bar)
900 - 1400 PSI (62.1 - 96.5 Bar)	60 PSI (4.14 Bar)

IMPORTANT: Read And Follow Steps 1-4 BEFORE Proceeding

- Place the controller in the "standby" mode.
- Close all valves marked "X".
- Open all valves marked "O".
- Place controller in the proper mode of operation as needed.

■ Open to build pressure to 60 psi (4.14 Bars) then close valve
* - Adjust as needed

	V2	V3	V4	V5	V6	V7	V8	V9	V10	V11	V12	V13	V14	V15	V16	V17
Normal Operation	X	X	X	X	O	O	*	X	X	O	O	O	X	O	O	O
System Purge	O	X	■	X	X	X	*	X	X	O	O	X	O	O	O	O
System Vent	O	O	X	O	X	X	*	X	X	O	O	X	O	O	X	O
Leak Test	O	O	O	X	X	X	*	X	X	O	O	X	O	O	X	O
Prime Pump	X	O	X	X	O	X	*	X	X	O	O	X	O	O	O	O

LEGEND

<ul style="list-style-type: none"> Normally Closed Valve Normally Open Valve Pneumatic Relay Check Valve Float Valve Pressure Gauge Electronic Level Transmitter Solenoid Valve Pressure Regulator w/Gauge Pressure Relief Valve Pressure Transmitter 	<ul style="list-style-type: none"> Liquid Odorant - Normal Operation Purge/Drain Line Expansion Line Intrinsically Safe Electrical Line Exhaust/Vent Line Actuation Line 75 psi (520 Kpa) Fill Valve Actuation Line Pump Actuation Line Odorant Actuation Gas 	<ul style="list-style-type: none"> V2 Purge Valve (Red Knob) V3 Prime Valve (Blue Knob) V4 Expansion Tank Pressure Supply Valve (Gold Knob) V5 Expansion Tank Vent Valve (Green Knob) V6 Expansion Tank Overflow Preventor Isolation Valve V7 Expansion Tank Overflow Preventor V8 Expansion Tank Fill Valve V9 Fill Rate Control Valve V10 Odorant Storage Tank 	<ul style="list-style-type: none"> V11 Odorant Storage Tank Vapor Return Valve V12 Odorant Storage Tank Relief Valve Isolation Valve V13 Odorant Storage Tank Blanket Gas Isolation Valve V14 Expansion Tank Drain Valve V15 Odorant Storage Tank Supply Isolation Valve V16 Gas Supply Isolation Valve (Black Knob) V17 System Odorant Supply Isolation Valve SV1 Pump Actuation Pilot Solenoid Valve SV2 Fill Valve Solenoid Valve PT1 Expansion Tank Pressure Transmitter PT2 Odorant Inlet Pressure Transmitter
---	---	---	--

SECTION 13: 6300G SYSTEM TROUBLESHOOTING

How to Use This Section

The recommendations contained in this section should be used as a preliminary information resource to remedy operational issues with the NJEX System. It is important to read all of the definitions and notes prior to initiating work.

Each sub-section contains a description of the alarm and non-alarm indicators followed by a step-by-step trouble shooting procedure.

For sub-sections containing information on alarms and non-alarm indicators, keep in mind that alarms will trigger the alarm relay output, and the red LED light on the display panel will flash. Non-alarm indicators will display on the LCD, cause the green LED to flash on and off and generate an entry in the Sentry reports but, will not trigger the alarm relay.

For Additional Help

Any issue that can not be resolved through the use of this reference, please contact YZ Technical Service at:

T: 1.800.653.9435 (1.800.NJEX-HELP)

T: 1.281.362.6500, International Calls

F: 1.281.362.6513

Em: TechSupport@yzhq.com

Assistance is available 24 hours a day, 7 days a week, 365 days a year, via the telephone numbers listed above.

SAFETY NOTES

- Always use extreme care when performing maintenance on an odorization system. Check to ensure the removal of liquid odorant and pressure from the portion of the system on which work will be performed prior to removing components or fittings.
 - Inspect all tube fittings and valve packings semi-annually to ensure that liquid odorant remains within the system.
-

Step-by-Step Resolution

Using a step-by-step method to resolve issues on the NJEX System will reduce maintenance time and assist in returning the odorization system to service quicker.

The following represent the recommended chronology to resolve issues:

1. Complete the Troubleshooting Form located in [Appendix C: Forms on page 114](#). Some of the information entered on the [For the Record Form on page 113 in Appendix C](#) can be of use.
2. Re-establish the correct pressures.
 - a. Expansion Tank, 25psi (1.72 Bar)
 - b. Bulk Storage Tank, 30-35psi (2.07-2.41 Bar)
 - c. Actuation Supply, 75psi (5.17 Bar)
 - d. Pump Actuation, refer to [figure 4, System Flow Schematic in Section 2: System Installation](#)
3. Resolve alarm issues to the following order:
 - a. Tank Level, [page 83](#)
 - b. Battery, [page 84](#)
 - c. Signal, [page 85](#)
 - d. Verometer, [page 86](#)
 - e. Pump, [page 91](#)

Tank Level Alarms

These alarms should only be active with skid mounted odorizer and tank assemblies furnished pre-assembled by YZ Systems, Inc. The set points for these alarms are adjustable in the parameter section of the N-300 controller.

- The **Odor Tank Low Level Alarm** should be set between 5% to 25%. This alarm indicates a tank level at or lower than the alarm set point.
- The **Odor Tank High Level Alarm** should be set between 80% to 90%. This alarm indicates a tank level at or above the alarm set point.

If your system was not purchased as a skid mounted assembly with a tank from YZ Systems, this alarm should be set to disabled in the alarm parameters section of the controller.

SECTION 13: 6300G SYSTEM TROUBLESHOOTING

Tank Level Alarm, *Continued*

IMPORTANT NOTE:

The tank level indication has a variance of $\pm 2\%$ for accuracy. If the alarm is on and the mechanical level indicator is close to the alarm set point the alarm is probably valid and the accuracy variance is all that is being noted.

Tank Level Alarm Troubleshooting Steps

1. Verify the tank level indication on the manual tank gage. If the level indication does not approximately match the electronic level indication perform the following checks.
 - a. Inspect to verify that the wiring to the controller termination strip **TB2** is still intact. Look for loose or broken wires at **TB2**, pin number **21** (*Red Wire*), **22** (*Black Wire*), and **24** (*Shield*). Repair any loose or broken wires.
 - b. Inspect the level sensor at the tank for possible damage or moisture in the sensor head. Repair or replace as required if moisture is inside the sensor.
 - c. Inspect the cable between the sensor and control head for damage. Repair or replace as necessary.
 - d. Observe the other values on the N-300 controller such as the temperature, battery voltage, and Verometer level, etc. for any unexpected values. If another value is found to be abnormal, inspect the bulkhead connector to interconnect cable connections for the presence of moisture or corrosion. If moisture or corrosion is found correct by replacing affected components. Simply cleaning the connection may not correct the problem temporarily or permanently.
2. If the level indication on the manual gage and the electronic level indication are approximately the same, within $\pm 2\%$ as indicated above, then the system is working correctly. If you wish to change the alarm set points, or disable the alarm, proceed to the Set Parameters section of the controller and make necessary changes to clear the alarm.

***ATEX units Low Battery Alarm indicates low voltage from customer supplied I.S. Power Supply.**

*Battery Alarm

- The **Low Battery Alarm** indicates that the battery or power supply voltage for the system has dropped below 11.5 volts.

Battery Alarm Troubleshooting Steps

1. First determine why the battery is low. For example, inspect for charging system issues, battery problems, or excessive current draw.
 - a. Disconnect the solar panel power supply cable (*Yellow cable*) from the lower bulkhead connection on the electronics enclosure.
 - b. Evaluate connections for any corrosion that may have prevented current from reaching the battery. If corrosion is found clean or replace affected components as necessary, and place back into service with a fully charged battery pack in place.
 - c. Test the output from the solar panel power supply cable (*yellow*) with a volt meter. Voltage from this cable should read 18 - 20VDC, when the sun is shining directly on the panel, or the Line Power Supply - LPS connected to AC current is in use. If voltage is low, service, or replace solar or LPS components as necessary.
 - d. If everything has checked out to this point, open the control panel assembly to expose the battery pack. Next un-plug the battery pack at the cable connection on the left side of the enclosure. Carefully read the voltage from the battery. Typically, the battery should read over 12.5VDC. If no reading is found here the fuse to the battery is blown and must be replaced. Contact YZ Systems for the a replacement.
 - e. Finally to evaluate for possible excessive current draw. Begin by disconnecting the cables one at a time to each solenoid and to the verometer. Note the change in voltage reading on the screen as any one cable is disconnected. Should you find one with a significant effect on the system voltage, that component should be replaced.

Note: Use only the originally specified fuse for replacement.

SECTION 13: 6300G SYSTEM TROUBLESHOOTING

2. If problem can not be resolved at this point contact YZ Systems Technical Service.

Signal Alarms

- The **Loss / Signal** alarm will be active only in the **Analog Proportional-To-Flow** mode. It indicates that the flow signal voltage has dropped below .5VDC. A correct flow signal should never drop below 1VDC.
- **Over Flow >125%** is an indication that the flow signal is showing greater than 125% of the maximum gas flow according to the set up conditions indicated in the parameter and calibration sections of the controller.

Signal Non-Alarm Signal Indicators

- **Low Flow** indicates that the flow, as indicated by the flow signal, has dropped to or below a level as indicated by the Low Flow Shutoff default parameter in the controller.
- **Over Flow >110%** is an indication that the flow signal is showing greater than 110% and less than 125% of maximum gas flow according to the set up conditions indicated in the Parameter and Calibration sections of the N-300 controller
- **No Flow** is an indication that the flow signal being received by the NJEX System currently reads a no flow situation in the pipeline and therefore no odorant is currently being injected. Odorization will automatically resume when the flow signal indicates flow in the pipeline.
- **Low Flow Shut Off** is an indication that the flow signal being received by the odorizer, indicates that present flow in the pipeline is less than the set value for the Low Flow shut Off set in the in the Parameter section of the N-300G . When the flow rate drops below this value odorant injection stops and therefore no odorization is presently occurring. Odorization will automatically resume when the flow signal returns to a level above the set point to stop odorization.

Signal Alarm & Non-Alarm Troubleshooting Steps

1. The **Loss of Flow** alarm will only be active with a Linear or Non-linear Analog signal. This alarm will be activated any time the flow signal goes completely away or drops below .5v (2Ma). Should this alarm occur check the flow signal on **TB2** pins **2** and **3** . Be certain the flow signal is connected to **TB2**, via the ten pin connector at pins **2** and **3**. If the signal is above .5v (2Ma), check your grounding system. If it is .5v (2Ma) or less, repair the flow signal source or cable as required.
2. The **Overflow** alarm will be indicated when the flow signal indicates 125% of the indicated span set point.
 - a. If reading an analog flow signal, linear or non-linear), a grounding reference error can cause this condition. Check that the grounding system is correctly in place. Read the flow signal voltage on **TB2** pins **2** and **3**. If the voltage reading on the volt meter is greater than 5v, the problem resides with the transmitted signal. Correct as necessary at the signal source. If the voltage on the volt meter is within the 1-5v range, the problem is most likely a grounding or isolation issue. This can be corrected by re-establishing the ground or installing a signal isolator device.
 - b. If the NJEX System is set to receive a pulse signal and this alarm activates, two issues could generate this alarm. First, the span frequency could be set incorrectly. Recalculate the span frequency and inspect the setting in the Calibration section of the N-300 Controller. The other cause could be the result of electrical noise interference resulting in the system interpreting this noise as pulses.
 - c. If it is believed this is in error or the situation continues to reoccur, the flow signal calibrations, and parameters should be re-calibrated with corrected values.

SECTION 13: 6300G SYSTEM TROUBLESHOOTING

Signal Alarm & Non-Alarm Troubleshooting Steps, *Continued*

3. **Low flow** indication is not an actual alarm, but an indication that the system is reading the flow signal to indicate the system is in the low flow shut off condition stipulated by the low flow shut off parameter. If it is felt this indicator should not be on, given the current flow, first check the parameter for the Low Flow Shut-Off to verify it is set as desired. As a second step, evaluate the flow signal being received. Verify that the signal indicates the correct flow, and that the signal spanned and zero referenced correctly. If necessary correct as required.
4. **Overflow** indicator will activate when the flow signal is showing greater than 110% and less than 125% of the maximum gas flow according to the set up conditions indicated in the parameter and calibration sections of the N-300 controller.
 - a. If reading an analog flow signal, linear or non-linear), a grounding reference error can cause this condition. Check that the grounding system is correctly in place. Read the flow signal voltage on **TB2** pins **2** and **3**. If the voltage reading on the volt meter is greater than 5v, the problem resides with the transmitted signal. Correct as necessary at the signal source. If the voltage on the volt meter is within the 1-5v range, the problem is most likely a grounding or isolation issue. This can be corrected by re-establishing the ground or installing a signal isolator device.
 - b. If the NJEX System is set to receive a pulse signal and receive this alarm, two issues could generate this alarm. First, the span frequency could be set incorrectly. Recalculate the span frequency and inspect the setting in the Calibration section of the N-300 Controller. The other cause could be the result of electrical noise interference resulting in the system interpreting this noise as pulses.

Verometer Alarms

There are a variety of Verometer alarms monitored by the N-300 Controller to ensure correct and safe operation of the NJEX System. The alarms relating to Verometer performance and their description is as follows:

- **Vmtr-Cable** alarm indicates a failure to communicate between the verometer and the N-300G controller.
- **No Fill** alarm is activated triggered if the Verometer fails to fill to 100% within 6 minutes after a fill is requested.
- **Slow Fill** alarm is indicated when a fill of the Verometer is requested and the Verometer does not fill to 100% within 3 minutes. This alarm actuates with either an automatic or manual fill request.
- **Leakage** is indicated when pump displacement is calculated with a greater than 50% above parameter safety. As if Verometer was leaking fluid and system will not continue to refill.
- **Fivalv-Fail** alarm indication is signaled if the level in the Verometer increases when a fill is not requested by the controller.
- **OdorInlet Cable** alarm indicates a failure to communicate between the fill valve pressure transducer on the Bulk Odorant Storage Tank side and the N-300G controller.
- **OdorInlet Lo** alarm indicates that the odorant pressure has dropped lower than defined in the set up parameters in the N-300G controller.
- **OdorInlet Hi** alarm indicates that the odorant pressure has exceeded the maximum pressure as defined in the set up parameters in the N-300G controller.
- **XTank - Cable** alarm indicates a failure to communicate between the Expansion Tank transducer on the fill valve assembly and the N-300G controller.
- **XTank Low** alarm indicates the pressure in the expansion tank has dropped below the defined minimum set point for the Expansion Tank.

SECTION 13: 6300G SYSTEM TROUBLESHOOTING

- **XTank High** alarm indicates the pressure in the expansion tank has exceeded the defined high pressure set point for the Expansion Tank.

Non-Alarm Verometer Indicators

- **Overfill** is indicated when the Verometer has filled to a level of 112% or greater.
- **Fillrate** alarm is indicated when the Verometer fills to 112% or greater in less than 10 seconds.

Verometer Troubleshooting Steps

1. Verify the following operating conditions, and correct as necessary:
 - a. Expansion tank pressure is set at 25 psi (1.72 Bar).
 - b. Bulk odorant storage tank pressure is at least 5 psi (.34 Bar) and not more than 10 psi (.69 Bar), above expansion tank pressure.
 - c. Actuation supply pressure is maintained during operation at 75 psi (5.17 Bar).
 - d. Verify that the bulk odorant storage tank has odorant and all valves are in the correct positions to allow the verometer to fill.
2. **Important:** Check and adjust the throttling valve position for effect on filling prior to proceeding to troubleshooting.

Restart the NJEX System to inspect the verometer for a fill. If no fill occurs, observe if a **No Fill** alarm is indicated under the Verometer display sequence and troubleshoot accordingly.

Verometer Cable Alarm Troubleshooting Steps

When an active **VMTR-Cable** alarm is indicated the following steps should be taken:

1. Inspect all cables for any external damage such as cuts or crimps in the external cable sleeve or moisture inside the cable connector.

2. Loosen and inspect the cable orientation pins for correct positioning. All cables have a specific mating connection to ensure that the correct pins on the opposing sides of the connector align. These pins must be correctly aligned to ensure the electronic signals reach the correct electronic address in the microprocessor.
3. Reconnect cables as noted above, ensuring that the alignment pins are mated correctly and that locking rings are tight. Observe if the alarm is still active, if it is, contact YZ Technical Services.

Verometer No-Fill Alarm Troubleshooting Steps

When an active **No-Fill** alarm is indicated the following steps should be taken:

IMPORTANT NOTE:

Before attempting to troubleshoot the fill valve, verify that the status switch is in the run position and the Verometer is not in a full level position. The fill valve commands can not be processed if the Verometer is full, or the status switch is in the standby position.

1. Check actuation gas supply filter and valves for possible restriction or closure, and adjust or replace as necessary.
2. Check odorant filters for possible restriction and replace as necessary.
3. Check tubing between bulk odorant storage tank and enclosure for damage. If tubing is crimped, bent or damaged by any form that could restrict flow, replace the tubing.
4. Test for adequate fill valve pneumatic actuation pressure. Place a gauge at the tubing connection located on top of the fill valve by disconnecting tubing. During a fill, the valve actuation pressure should be 75 psi (5.17 Bar).

SECTION 13: 6300G SYSTEM TROUBLESHOOTING

Verometer No-Fill Alarm Troubleshooting Steps, *Continued*

5. Verify that the status switch be in the run position. If no pneumatic supply is received at the fill valve when a fill is called for, test electrical supply to the fill valve solenoid located on the left. With a volt meter the current should read 12VDC at the fill valve solenoid when a fill is requested. If voltage is present when a fill is requested, but gas will not flow to the fill valve, replace the solenoid.
 - a. If a volt meter is unavailable, you may test fire the pump with the test switch to verify the other solenoid and cable are active. To test, temporarily switch the solenoid cables. Now when the test switch is activated, the fill valve solenoid should send pneumatic supply gas to the loosened connection at the fill valve for approximately .2 seconds each time the test switch is activated. If this does occur there is some problem with the fill signal getting to the fill solenoid. However, if the solenoid still does not send actuation gas to the fill valve the solenoid is bad and should be replaced.

If the signal is not getting to the solenoid, test at terminal strip **TB2**, located inside the termination enclosure just below the N-300 Controller, with a volt meter at pins **7** positive (*orange wire*) and **8** negative (*violet wire*), for 12VDC when the fill is requested from the N-300 controller. If the voltage is present, check the wiring for proper polarity connections. Verify that pin **7** has an orange wire, and pin **8** a violet wire connected.

6. If an electrical signal is not present when a fill is requested, check all cables for corrosion, moisture, or damage and replace if any signs of the previous mentioned problems are present and perform the test again.
7. If an electrical signal is still not present contact YZ Systems Technical Service.

Verometer Slow-Fill Alarm Troubleshooting Steps

IMPORTANT NOTE:

Prior to troubleshooting a slow fill alarm, verify that the Verometer is not in a full level position as the fill valve commands can not be processed if the Verometer is full.

1. Inspect the actuation gas supply filter for possible restriction, and replace as necessary.
2. Inspect the odorant filters for possible restriction and replace as necessary.
3. Check tubing between bulk odorant storage tank and enclosure for damage. If tubing is crimped, bent or damaged by any form that could restrict flow, replace the tubing. Verify that an adequate flow of odorant is supplied to the fill valve.
4. Test for adequate fill valve pneumatic actuation pressure. Place a guage at the tubing connection located on top of the fill valve by disconnecting tubing. During a fill, the valve actuation pressure should be 75 psi (5.17 Bar).
5. Disassemble, clean, and rebuild fill valve assembly.

Verometer Leakage Alarm Troubleshooting Steps

1. Inspect the system for any obvious leaks and repair as necessary.
2. If the **Leakage** alarm occurs during purging of the system or the packing of the lines with odorant on a new system, a manual refill of the verometer will be required and this will clear the alarm.
3. Verify that the pump displacement parameter correctly matches the actual pump performance on the system, and correct if necessary.
4. Verify the correct balance of pressures between the pump actuation pressure and the pipeline pressure, *refer to figure 4, in the System Flow Schematic on page 6, Section 2: System Installation* for specific system pressures.

SECTION 13: 6300G SYSTEM TROUBLESHOOTING

5. If the pipeline pressure is near or below 250 psi (17.24 Bar), a back pressure regulating device must be installed immediately outside the NJEX enclosure, on the odorant line leading to the pipeline injection point. If this device is installed, verify that it is maintaining a back pressure regulating device above 250 psi (17.24 Bar).
6. Verify that the total run of tubing from the pipeline to the NJEX System does not exceed 15' (4.5 Meters).

Verometer Fill Valve Failure Alarm Troubleshooting Steps

When an active **Flvalv-Fail** alarm is indicated the following steps should be taken:

CAUTION:

Verify the following prior to commencing work:

1. *Actuation pressure is not excessive. This can cause the fill valve solenoid to open slightly when the pump strokes, which would open the fill valve and trigger an alarm.*
2. *Verify that all valves in the system are in the correct position. A valve in the incorrect position may allow odorant to enter the Verometer via a path other than through the fill valve, resulting in a fill valve alarm. For example, if valves V2 and V3 were left open, the result would cause a fill valve alarm.*

Verometer at 116%

1. Initiate a forward purge to lower Verometer level to approximately 50% and return the NJEX System to normal operating pressures and valve positions.
2. Place the NJEX System in standby mode and observe level changes in the Verometer by monitoring the Verometer level status on the N-300 controller display.
3. If the level increases disconnect the pneumatic supply tube at the top of the fill valve to inspect if actuation gas is present. If actuation gas is not present when the tube is disconnected, and the Verometer level continues to increase, repair or

replace the fill valve. If the actuation gas is present in the tube when disconnected, the Verometer level should stabilize after disconnecting the fill valve pneumatic supply tube. Proceed to step 4.

4. While the fill valve pneumatic supply tube is disconnected, toggle the mode switch from run to standby and back again. This should stop and start the pneumatic supply.
 - a. If the pneumatic supply stays on, disconnect the fill valve solenoid cable. If disconnecting the cable does not stop the pneumatic supply, replace the solenoid.
 - b. If disconnecting the cable in step 4a listed above caused the pneumatic supply to stop, check the electrical connections for the presence of moisture. Dry the connections if moisture is present and try test again. If moisture on the solenoid was not the problem, check the interconnect cable for possible moisture or corrosion where it connects to the mechanical enclosure. Replace if corrosion or moisture is present.
5. If the step taken above do not resolve the issue entire control head assembly must be replaced.

Verometer Odorant Inlet Cable Alarm Troubleshooting Steps

When an active **OdorInlet-Cable** alarm is indicated the following steps should be taken:

1. Inspect all cables for any external damage such as cuts or crimps in the external cable sleeve or moisture inside the cable connector.
2. Loosen and inspect the cable orientation pins for correct positioning. All cables have a specific mating connection to ensure that the correct pins on the opposing sides of the connector align. These pins must be correctly aligned to ensure the electronic signals reach the correct electronic address in the microprocessor.
3. Reconnect cables as noted above, ensuring that the alignment pins are mated correctly and that locking rings are tight. Observe if the alarm is still active, if it is, contact YZ Technical Services.

SECTION 13: 6300G SYSTEM TROUBLESHOOTING

Verometer Odorant Inlet Low Alarm Troubleshooting Steps

When an active **OdorInlet Lo** alarm is indicated the following steps should be taken:

1. Verify that the bulk odorant storage tank pressure exists in a range of 30 to 35 psi (2.07 to 2.41 Bar) and re-establish the correct pressure if necessary.
2. Inspect the alarm set point programmed into the N-300 controller and verify that it is correctly programmed and correct if necessary, [refer to the parameters section on programming the N-300 controller Sections 5 & 6, page 25 or page 33 depending on the mode of operation.](#)
3. Observe if the alarm is still active, if it is, contact YZ Technical Services.

Verometer Odorant Inlet Hi Alarm Troubleshooting Steps

When an active **OdorInlet Hi** alarm is indicated the following steps should be taken:

1. Verify that the bulk odorant storage tank pressure exists in a range of 30 to 35 psi (2.07 to 2.41 Bar) and re-establish the correct pressure if necessary.
2. Inspect the alarm set point programmed into the N-300 controller and verify that it is correctly programmed and correct if necessary, [refer to the parameters section on programming the N-300 controller Sections 5 & 6, page 25 or page 33 depending on the mode of operation.](#)
3. Observe if the alarm is still active, if it is, contact YZ Technical Services.

Verometer Expansion Tank Cable Alarm Troubleshooting Steps

When an active **XTank-Cable** alarm is indicated the following steps should be taken:

1. Inspect all cables for any external damage such as cuts or crimps in the external cable sleeve or moisture inside the cable connector.
2. Loosen and inspect the cable orientation pins for correct positioning. All cables have a specific mating connection to ensure that the correct pins on the opposing sides of the connector align. These pins must be correctly aligned to ensure the electronic signals reach the correct electronic address in the microprocessor.
3. Reconnect cables as noted above, ensuring that the alignment pins are mated correctly and that locking rings are tight. Observe if the alarm is still active, if it is, contact YZ Technical Services.

Verometer Expansion Tank Low Alarm Troubleshooting Steps

When an active **XTank Low** alarm is indicated the following steps should be taken:

1. Verify that the expansion tank pressure is at 25 psi (1.72 Bar) and correct if necessary.
2. Inspect the alarm set point programmed into the N-300 controller and verify that it is correctly programmed and correct if necessary, [refer to the parameters section on programming the N-300 controller Sections 5 & 6, page 25 or page 33 depending on the mode of operation.](#)
3. Observe if the alarm is still active, if it is, contact YZ Technical Services.

SECTION 13: 6300G SYSTEM TROUBLESHOOTING

Verometer Expansion Tank High Alarm Troubleshooting Steps

When an active **XTank High** alarm is indicated the following steps should be taken:

1. Verify that the expansion tank pressure is at 25 psi (1.72 Bar) and correct if necessary.
2. Inspect the alarm set point programmed into the N-300 controller and verify that it is correctly programmed and correct if necessary, [refer to the parameters section on programming the N-300 controller Sections 5 & 6, page 28 or page 35 depending on the mode of operation.](#)
3. Observe if the alarm is still active, if it is, contact YZ Technical Services.

Verometer Overfill Non-Alarm Indicator Troubleshooting Steps

When an active **Overfill** non-alarm is indicated the following steps should be taken:

IMPORTANT NOTE:

Prior to troubleshooting an overfill indicator verify that the Verometer is not in a full level position as the fill valve commands can not be processed if the Verometer is full.

1. Empty the Verometer by performing a forward purge.
2. After returning all pressures and valves to their normal operating position. Observe the Verometer level for 5 -10 minutes and note if a change in the Verometer level occurs without operator influence. If level in the Verometer does increase without operator influence, [proceed to the Fill Valve Trouble- shooting section of this manual on page 89.](#) If the level in the Verometer does not increase then otherwise proceed to the next step below.
3. Initiate a Verometer fill and record the time required to fill to 100%, and note the level. If the Verometer fills in a time faster than 30 seconds, partially close the volume throttling valve between

the odorant storage tank and the NJEX System. This should slow the fill rate. Repeat step 3 until the NJEX System fills in over 30 seconds, and the fill valve turns off between 100 - 108% of fill volume.

Verometer Fill Rate Non-Alarm Indicator Troubleshooting Steps

When an active **Fillrate** non-alarm is indicated the following steps should be taken:

1. Verify the correct set points on the following pressures.
 - a. Expansion Tank set at 25 psi (1.72 Bar)
 - b. Bulk Tank set at 30 - 36 psi (2.07-2.41 Bar)
 - c. System Supply set at 75 psi (5.17 Bar)
2. Empty the Verometer by performing a forward purge. Re-establish the pressures and valves to their normal operating position, and then proceed to step 3.
3. Perform the Verometer fill procedure as indicated in [Section 12: System Maintenance, page 78,](#) and adjust fill rate control valve **V9** to achieve a appropriate fill rate.

Pump Alarms

There are three pump alarms monitored by the N-300 Controller to ensure correct and safe operation of the NJEX System. The alarms relating to the pump performance and their description is as follows:

- **Over Pump** alarm will indicate if the actual pump displacement exceeds the programed pump displacement value by 30%.
- **Under Pump** alarm will indicate when the actual pump displacement ranges from 30 - 75% of the programed pump displacement value.
- **Pump Failure** alarm will indicate when the actual pump displacement is less than 25% of the programed pump displacement value.

SECTION 13: 6300G SYSTEM TROUBLESHOOTING

IMPORTANT NOTE:

When a system re-start is requested at completion or during the the service of an NJEX System, use the N-300 controller to stop and restart the system from the main menu.

*After a restart, the default values will be used for operation, and alarms will be cleared until actual performance values can be ascertained by the N-300 controller. In the case of the pump displacement this may not occur until the pump has drained the Verometer to approximately the 90% level. An * will appear by the indicated pump displacement after a stop and restart. This indicates that the displayed value is a default parameter value, which is not a real pump performance indication. As a result, this default pump performance indication should not be relied upon as the actual pump performance.*

Do not prematurely assume the problem has been resolved, simply due to the disappearance of the indicators and alarms immediately after a re-start of the NJEX System.

Pump Over Pumping Alarm Troubleshooting Steps

When an active **Over Pumping** alarm is indicated the following steps should be taken:

1. This alarm may occur after service or maintenance has been performed due to variances in the Verometer level during the conduct of service. If service has recently been performed, and this alarm occurs, stop and restart the system to observe if the alarm re-occurs, thus indicating a real alarm. If the alarm re-occurs continue to step 2 below.
2. Verify that the operating conditions remain unchanged and correct as needed. The pipeline pressure should be at least 250 psi (17.24 Bar).
 - a. Inspect the installation for the use of a back pressure regulating device. For pipeline pressures less than 250 psi (17.24 Bar) a back pressure regulating device must be installed immediately outside the NJEX enclosure on the odorant line leading to the pipeline injection point. A back pressure regulating device can alleviate the over pumping conditions that

can result by the varying pressures and temperatures in the pipeline for pressures less than 250 psi (17.4 Bar). If a back pressure regulating device is not installed as described above, install the device before proceeding.

- b. If line pressure is less than 250 psi (17.24 Bar) and a back pressure regulating device is installed on the odorant injection line, inspect the back pressure regulating device for proper operation, and installation as described above.
3. Verify that the actuation pressure remains unchanged from previous setting.
4. Verify the pump displacement parameter setting is the same as the desired pump displacement.

Pump Under Pumping Alarm Troubleshooting Steps

When an active **Under Pumping** alarm is indicated the following steps should be taken:

1. If maintenance or repair has just been performed, stop and restart the system to see if the alarm re-occurs indicating a real alarm. If the alarm re-occurs continue to the next step.
2. Verify operating conditions. Correct as needed.
3. Verify that the pump displacement parameter matches the accurate pump displacement.

Note: *When starting a system for the first time the expected pump displacement should be set in the N300G controller parameters section. The system should then be run through at least one complete Verometer cycle to get an accurate pump displacement reading. Actual installation conditions may have an effect on the real pump performance. Use the accurate pump displacement as calculated by the controller for the final pump displacement parameter to be entered into the controller.*

4. Check to see if the pump operation sounds the same as previously. A distinct bottoming of the plunger piston and return a return to the top of the plunger piston housing should be audible with each actuation. If not, remove the actuation cylinder. Inspect for a broken return spring, or a stuck / sticking actuator

SECTION 13: 6300G SYSTEM TROUBLESHOOTING

- piston or plunger. Replace the spring if broken. Clean and Lubricate the actuation cylinder and actuation piston assembly. Manually push the plunger into the seal assembly and ensure it returns completely and freely. If sticking continues to occur, the seals should be replaced. Reassemble and see if alarm reoccurs after a system restart.
5. If pump actuation is normal:
 - a. Inspect the discharge lines and valves for a restriction.
 - b. Inspect all the check valves on the discharge side of the pump, from the NJEX System to the pipeline, for proper operation.
 - c. A back pressure regulating device must be installed immediately outside the NJEX enclosure on the odorant line leading to the pipeline injection point. Perform a forward purge noting the time required to empty the Verometer. If the time to empty the Verometer is longer than 30-45 seconds, after the level begins dropping, replace the Verometer filter, and restart the system. During the system restart monitor the controller and observe if the alarm reoccurs.
 - d. Replace the inlet check valve to the pump.
 6. If problems persist, contact YZ technical service for additional assistance.

Pump Failure Alarm Troubleshooting Steps

When an active **Pump Failure** alarm is indicated the following steps should be taken:

1. Verify that the Verometer has odorant in it, and that the expansion tank has the proper pressure in it of 25 psi (1.72 Bar).

Note: *If the Verometer is empty, restart the system. Stroke to the pump to cyle odorant through the system and observe if the alarm reoccurs.*

2. Verify that the pump volume spacer matches the pump displacement parameter in the controller.
3. Verify that all valves and check valves are properly set system operation. Inspect for valve settings that can restrict pump displacement.
4. Check the actuation gas filter for flow restriction or closure.
5. Ascertain whether the pump is properly stroking.
 - a. If pump actuation does not occur as the Test key is pressed, remove the actuation gas line at the top of the pump and test the pump stroke again. As the **Test** key is pressed, there should be a burst of gas at the open actuation supply connection. If gas is released from the open actuation supply line skip to subsection **5.g.** , otherwise continue to **5.b.**
 - b. If gas is not blown from the loose connection, disconnect the hose leading from the pump solenoid to air relay valve. Test stroke the pump again and observe if gas is discharged from the small hose.
 - c. If gas comes out of the solenoid briefly when the **Test** key is pressed the solenoid is good but, the air relay valve requires service or repair.
 - d. If small hose does not release gas, remove the pump solenoid wiring cable, the solenoid located on the right of the two solenoids. Next, connect a volt meter to the two parallel posts of the solenoid cable. As the **Test** key is pressed, observe if a 12VDC current becomes present. If a voltage is detected the solenoid should be replaced.

If a volt meter is unavailable, the fill valve signal may be used to test the solenoid. First, test the fill valve function to verify that it is working properly before using it to test the pump solenoid. Second, verify that the Verometer is less than 100 % full on the level

SECTION 13: 6300G SYSTEM TROUBLESHOOTING

indication. Third, take the cable connected to the fill valve solenoid, remove it and re-connect it to the pump solenoid. With the status key in the run mode instruct the NJEX System to fill. If the solenoid is good, you should get gas from the solenoid. To stop it, place in the NJEX System in standby mode and gas flow should stop. If no gas flows the pump solenoid is bad and should be replaced.

- e. If the above test indicates the solenoid is functioning, next determine if the signal is being sent by the controller, or lost in the cabling and connections. Open the termination enclosure, enclosure door just below the N-300, and connect your volt meter to **TB2** terminals **9** and **10**, with **9** being the positive (yellow wire) and **10** being the negative (blue wire). Now, test fire the pump with the test switch. A momentary voltage pulse, approximately .2 seconds in duration, should be observed. This will be a DC voltage pulse not exceeding 12VDC. If the pulse is at the termination panel next check the polarity of connections of the wiring. The terminal **9** should have a yellow wire attached and, the terminal **10** should have a blue wire attached. If the polarity is correct, on the wiring, the cable assembly to the solenoid should be replaced.
 - f. If no voltage is detected, contact the technical service department at the factory.
 - g. With the actuation gas line reconnected to the pump, test stroke the pump. Observe if there is an audible pump stroke with the piston bottoming out and returning to the top of the pump housing. If an audible pump actuation is not present, remove the actuation cylinder and inspect for a broken return spring, or a stuck / sticking plunger assembly. Replace the spring if broken, clean and relubricate the plunger assembly and actuation cylinder. Make certain the seals are not sticking to the plunger assembly.
6. Assure that the pump is properly primed by:
 - a. Placing the unit in stand by.
 - b. Closing valve **V8** at the pipeline.
 - c. Open valve **V3**.
 - d. Test stroke the pump 15 - 20 strokes with the **Test** key, then place back in standby.
 - e. Close valve **V3** and open valve **V8**.
 - f. Place the controller in run mode.
 - g. Monitor the pump performance and observe if pump actuation is occurring.
 7. If problems persist, contact YZ technical service for additional assistance.

APPENDIX A: ILLUSTRATIONS

NJEX Model 6000 pump

Assembled, *Figure 201*

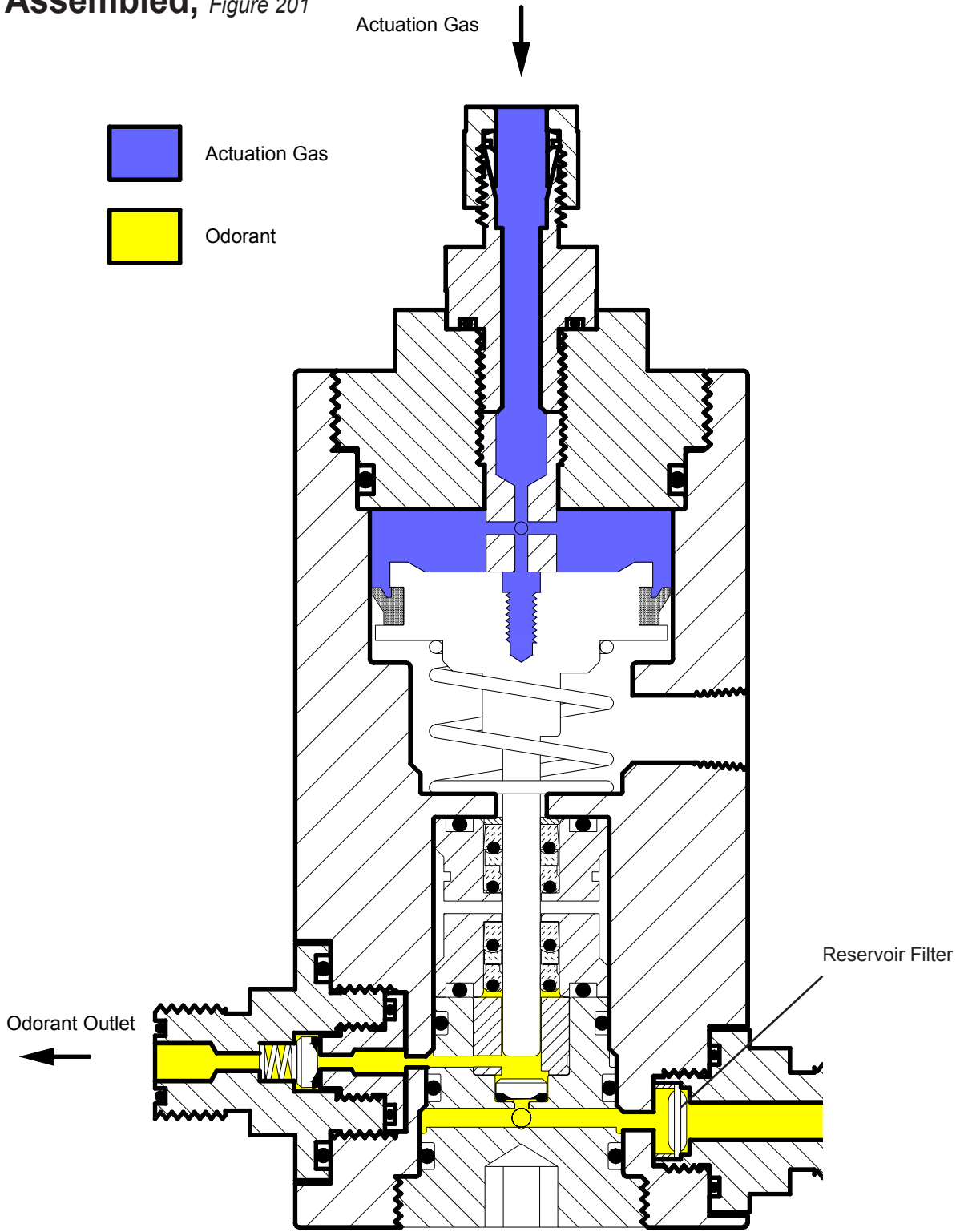

6000 Pump Repair Kit (P/N D3-0140)

APPENDIX A: ILLUSTRATIONS

NJEX Model 6000 Pump

Actuation Assembly,

Exploded View, *Figure 202*

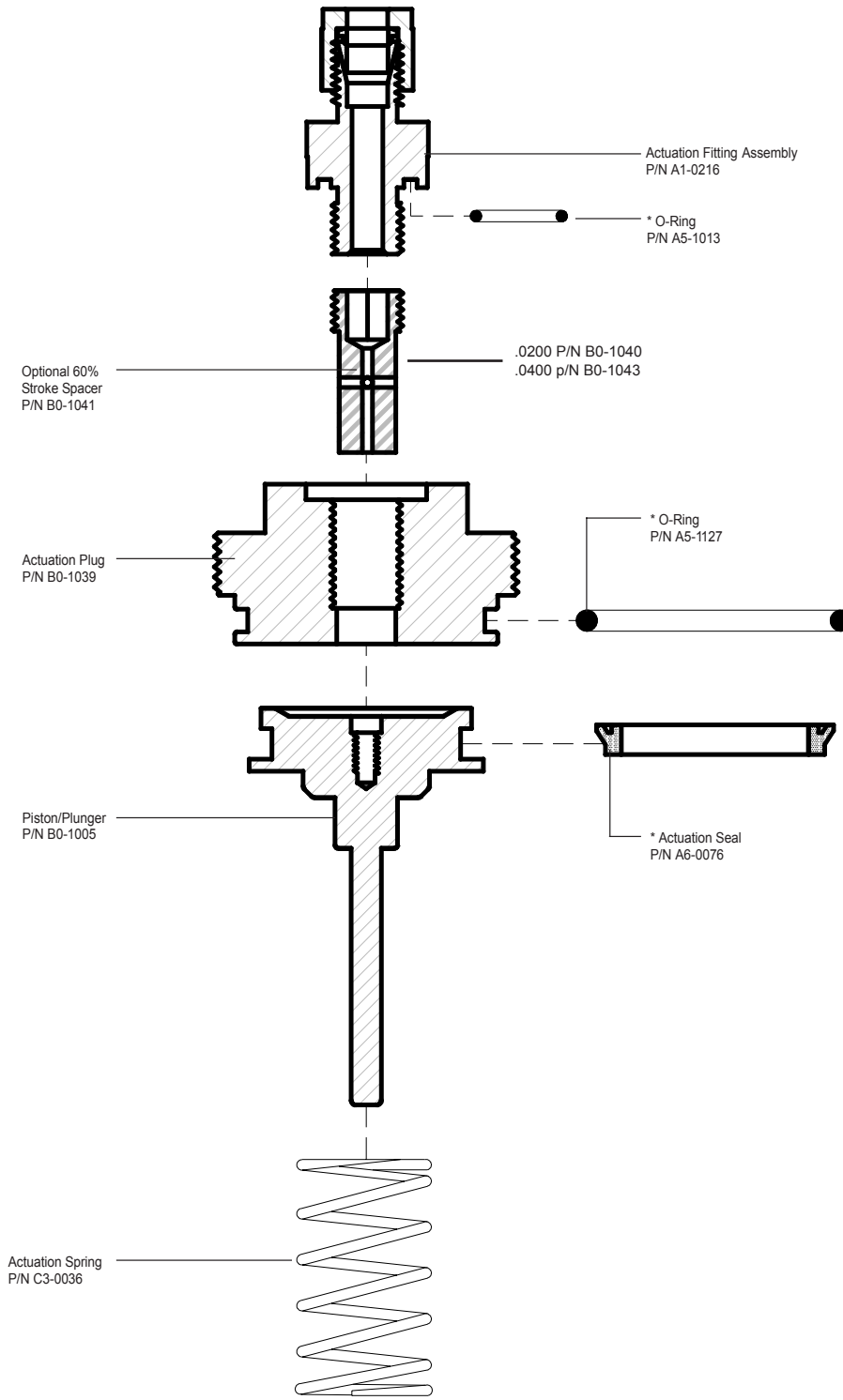

*6000B Pump Repair Kit (P/N D3-0140)

APPENDIX A: ILLUSTRATIONS

NJEX Model 6000 Pump

Check Valve Assemblies, and Seals,

Exploded View, *Figure 203*

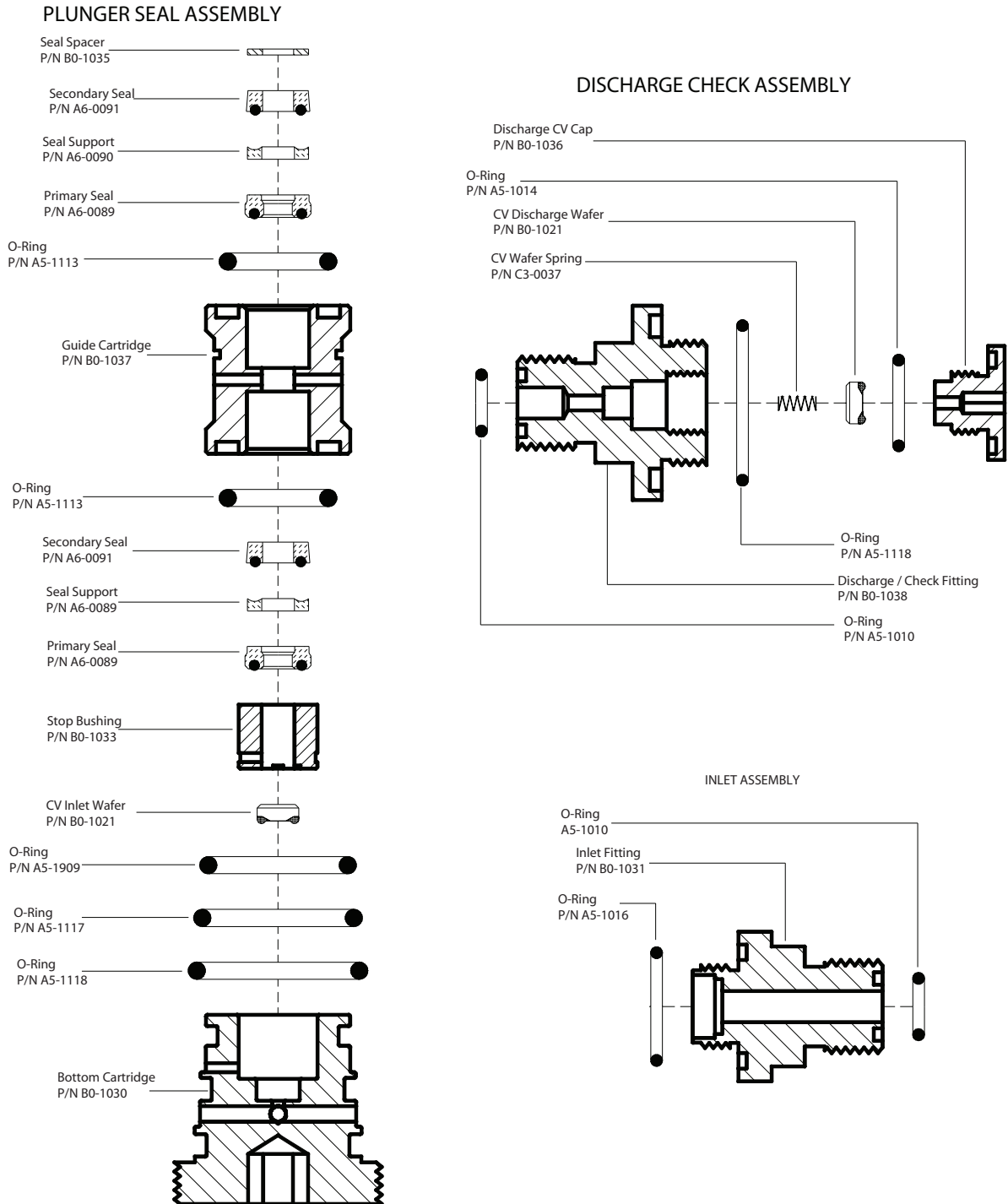

*6000B Pump Repair Kit (P/N D3-0140)

APPENDIX A: ILLUSTRATIONS

Fill Valve, Exploded View,

Figure 204

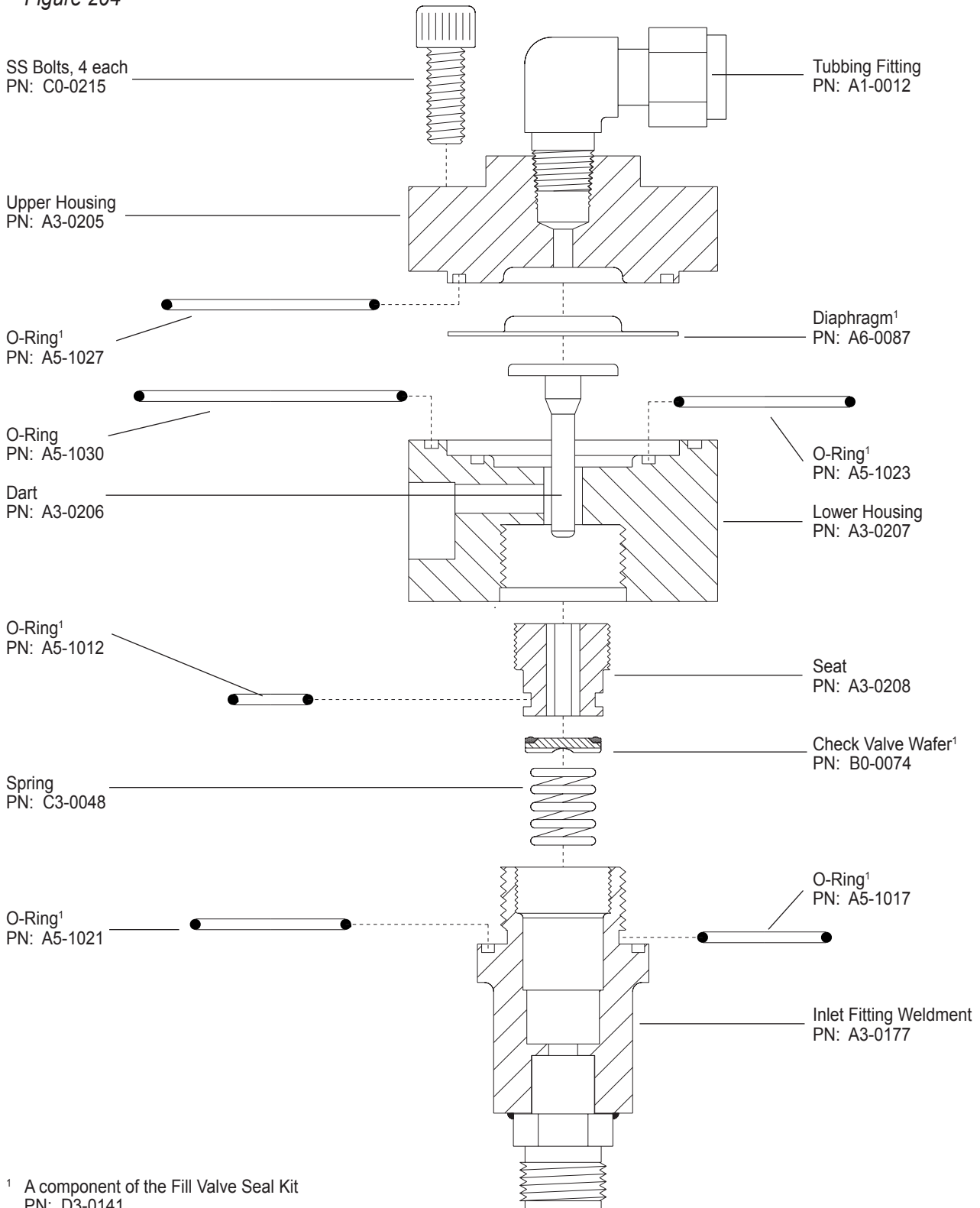

APPENDIX A: ILLUSTRATIONS

VM-1000 Verometer, with Filter Assembly Exploded View, *Figure 205*

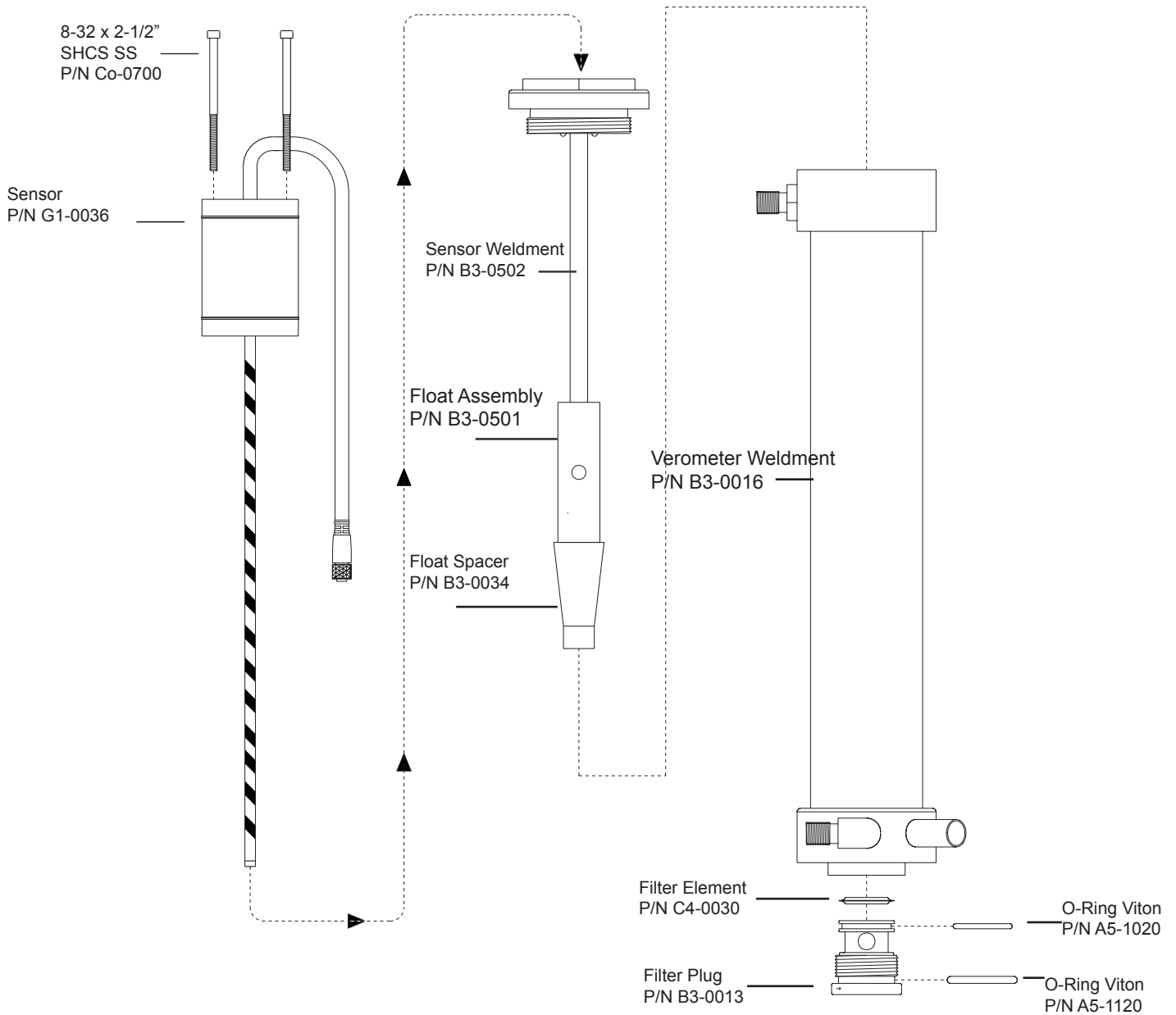

Verometer Filter Element Kit (P/N D3-0126)

APPENDIX A: ILLUSTRATIONS

Bulk Odorant Filter

Figure 206

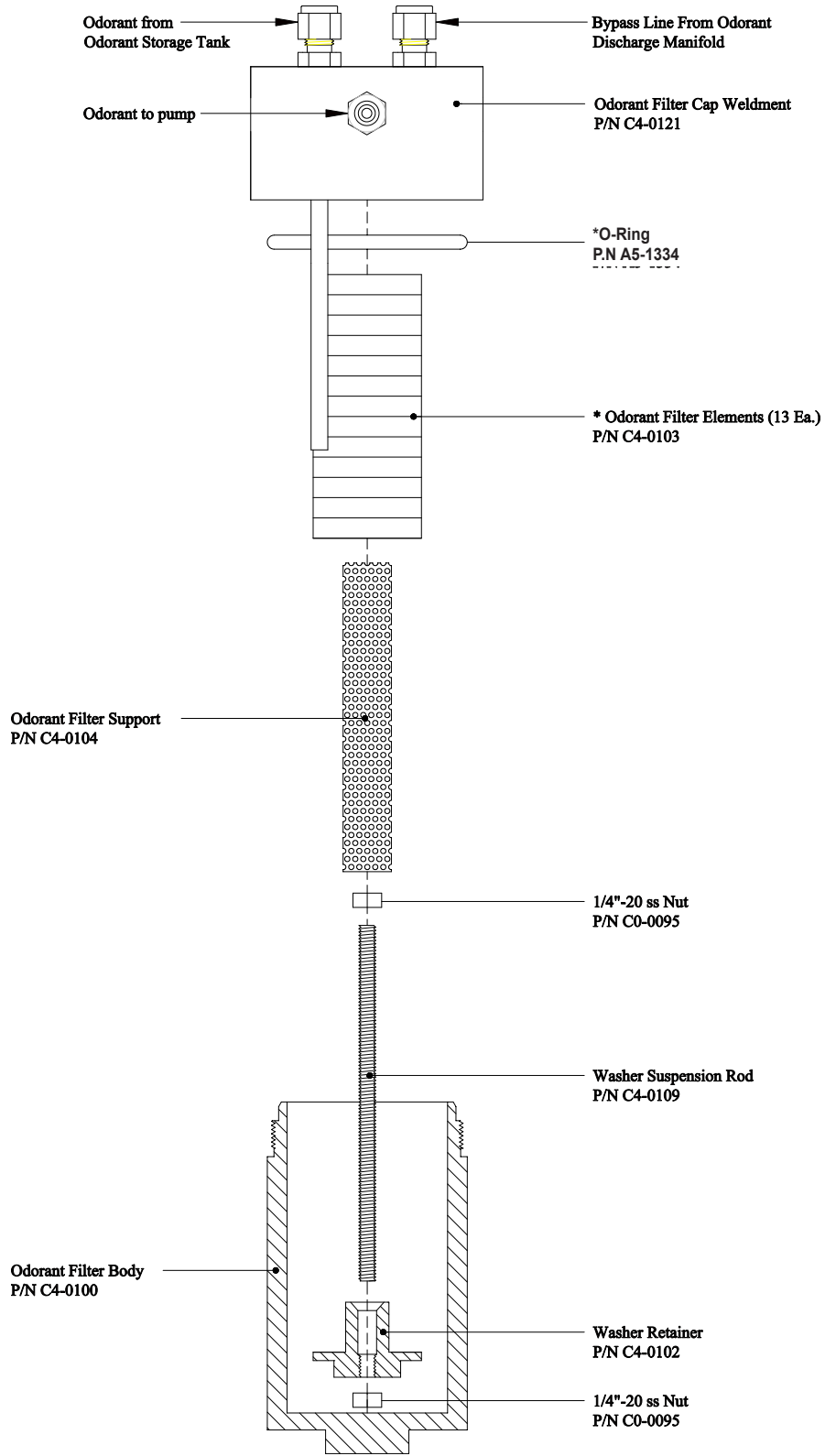

*Bulk Odorant Filter Element Replacement Kit (P/N D3-0103)

APPENDIX A: ILLUSTRATIONS

NJEX Gas Filter

Figure 207

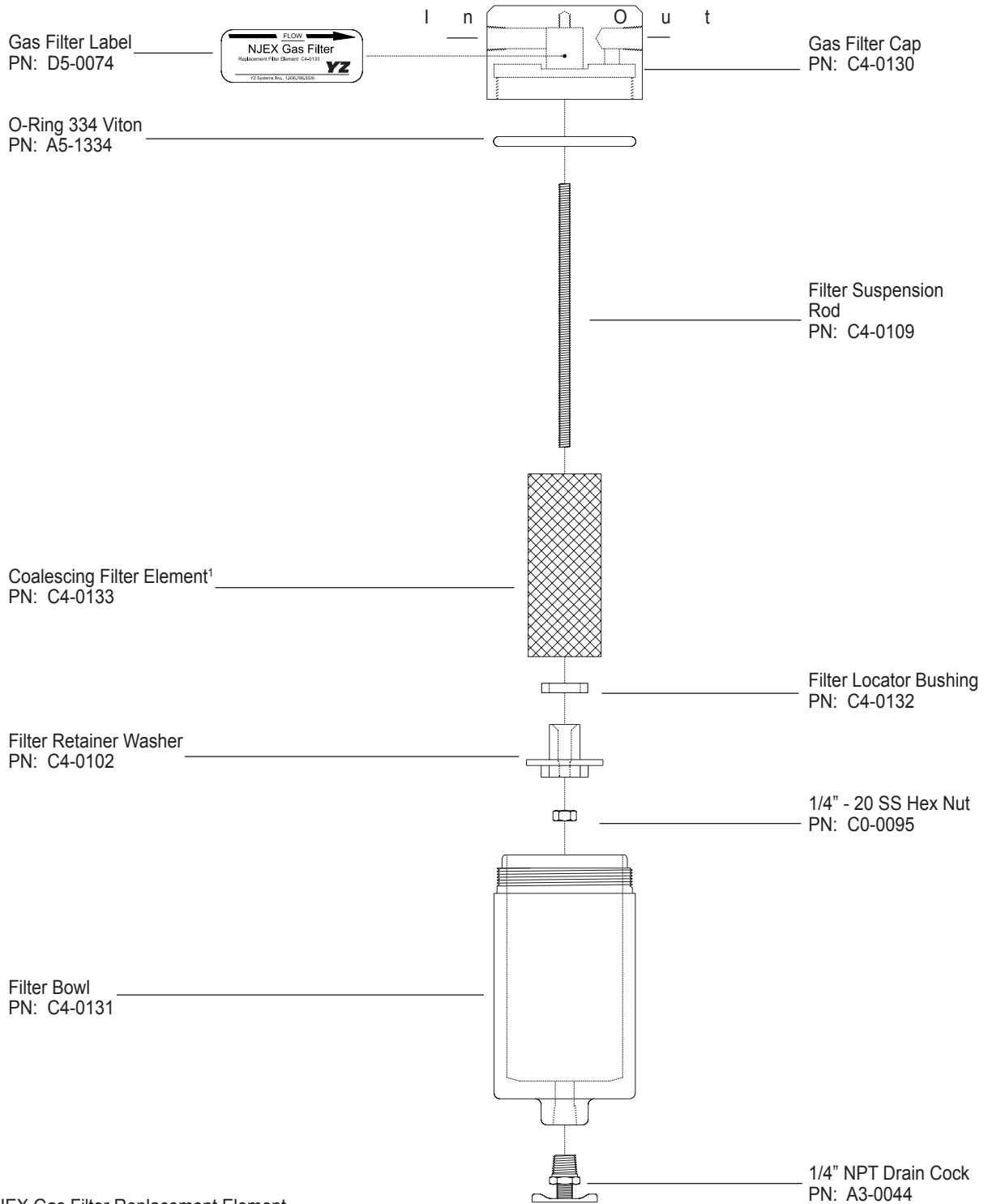

¹ NJEX Gas Filter Replacement Element
PN: C4-0133

APPENDIX A: ILLUSTRATIONS

Electronics Assembly

Figure 208



APPENDIX A: ILLUSTRATIONS

*SPS-12 Solar Power Supply Unit

Figure 209

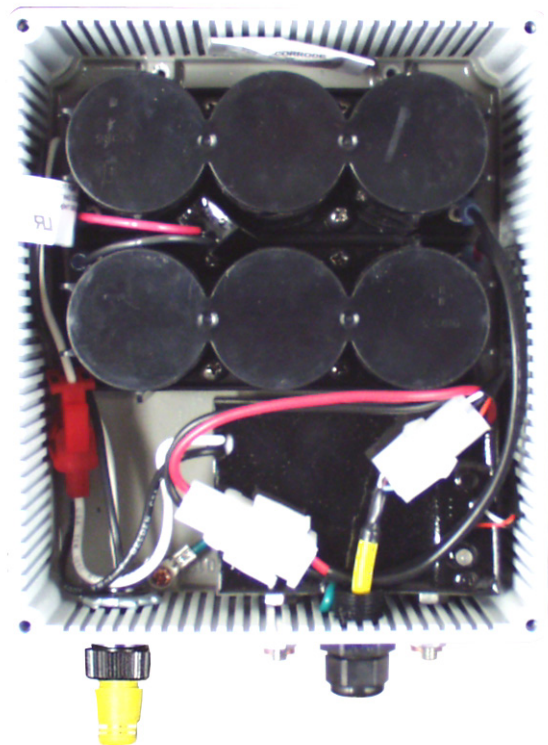
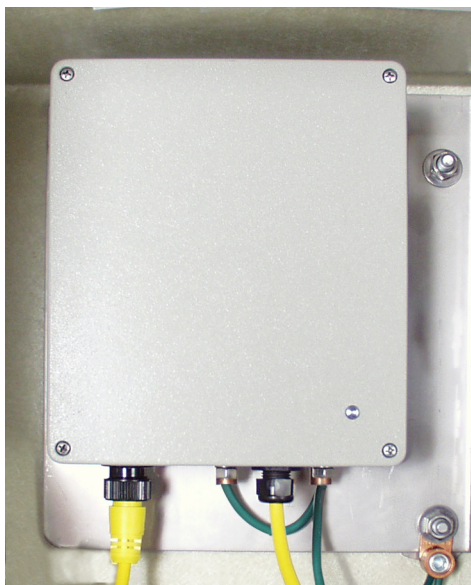
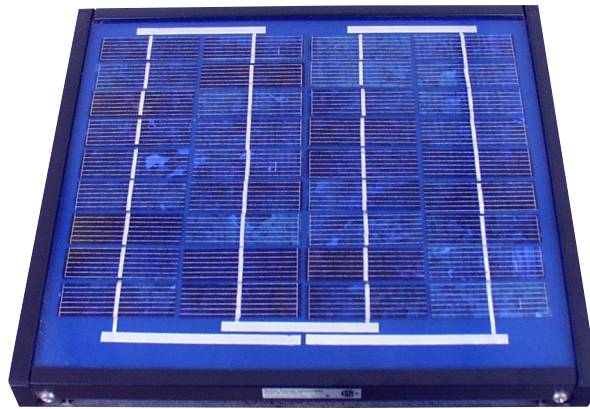

***Not included with ATEX units**

APPENDIX A: ILLUSTRATIONS

*LPS-120/240 Charger Supply Unit, *Figure 210*

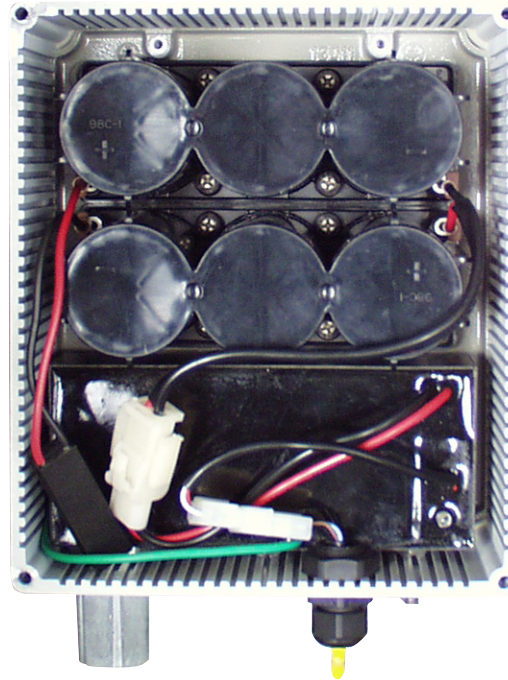
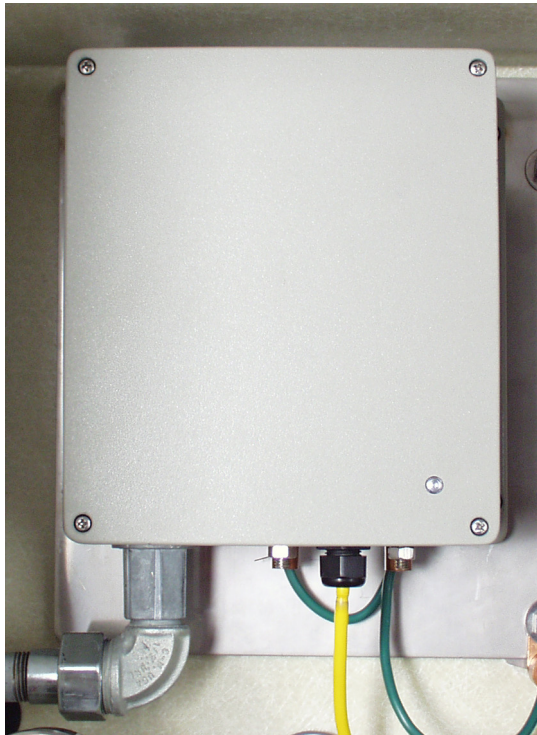

***Not included with ATEX units**

APPENDIX A: ILLUSTRATIONS

Heater Wiring Diagram

Optional, *Figure 211*

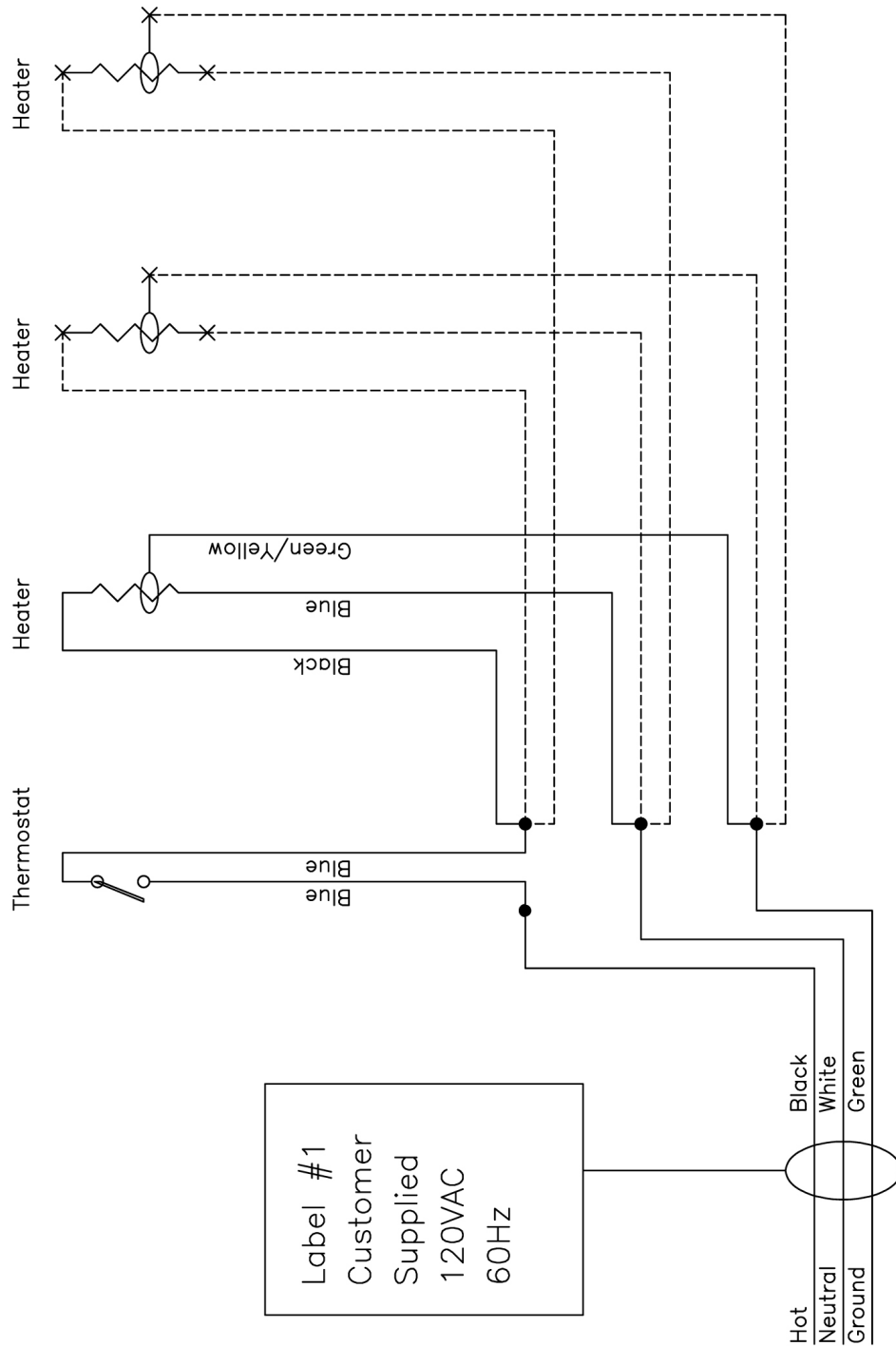

APPENDIX B: N-300 MODBUS SPECIFICATIONS

Communications Settings

Protocol	Modbus
Data framing	Modbus RTU and ASCII
Slave Address range	0-247, 0 = Modbus disabled
Baud rates	1200, 2400, 4800, and 9600
Number of data bits	7 or 8
Parity	None, Odd, Even
Stop bits:	1 or 2
Serial communications:	Redundant RS-485 2 wire

N300 Modbus Function Support

Function Code	Function	Description
1.....	Read Coil Status.....	Reads the ON/OFF status of discrete outputs (coils)
3.....	Read Holding Registers.....	Reads the binary contents of holding registers
5.....	Force Single Coil	Forces a single coil to either the ON or OFF state
6.....	Preset Single Registers	Presets a value into a single holding register
16.....	Preset Multiple Registers	Presets values into a sequence of holding registers

Boolean Registers

The Boolean data type could be used for status, and control. The discrete outputs or “coils” as defined by the Modbus specification are read/write registers. This ON/OFF data type can be manipulated using Modbus functions 1 and 5.

The valid address range for this data type is 00001 to 09999.

Function 1, allows reading a single coil per query

Function 5, allows writing single or multiple coils per query.

Control Functions

The control functions available via Modbus are listed below. The registers are accessed using Modbus functions 1 and 5. The master device can initiate a state change by setting a control coil. The N300 controller will clear non-toggle type coils to acknowledge the state change has been acted upon. Toggle type coils hold their current state until changed either locally or remotely. The local/remote load cycle control (00007) determines whether a load cycle can be initiated via contact closure (local) connected to the load cycle inputs on the controller or by Modbus coil 00006 (remote). These coils are only active in an N300 Liquid system. Coil 00011 determines whether a remote inhibit can be initiated by a contact closure (local) connected to the inhibit inputs on the controller or by Modbus coil 00010 (remote). Coil 00009 is used to save all the current parameters to the controller EEPROM.

IMPORTANT:

Coil 00009, must be used to save any parameters that were changed via Modbus.

Address	Access	Description
00001.....	Read/Write.....	Start/Stop the pump (toggle)
00002.....	Read/Write.....	System Standby (toggle)
00003.....	Read/Write.....	Reset Accumulated Stroke Count
00004.....	Read/Write.....	Reset Accumulated Odorant Injected
00005.....	Read/Write.....	Fill Verometer (toggle)
00006.....	Read/Write.....	Start/Stop a Load Cycle (toggle) (Liquid System Only)

APPENDIX B: N-300 MODBUS SPECIFICATIONS

Boolean Registers

Control Functions, *Continued*

Address	Access	Description
00007.....	Read/Write.....	Local/Remote Load Cycle Control (toggle) (Liquid System Only)
00008.....	Read/Write.....	Proportional to Time/Flow mode (toggle)
00009.....	Read/Write.....	Save Parameters to EEPROM
00010.....	Read/Write.....	Remote Inhibit / Run the N-300 (toggle)
00011.....	Read/Write.....	Local/Remote Inhibit Control (toggle)

Status Functions

The status functions available via Modbus are listed below. The registers are accessed using Modbus function 1. Status labeled with an "L" after the Access types are latching type status. A latching status provides a "since the last read" type status where a set condition will hold it's state until a read of that particular register was made by the master device. Once a read is made, the status will reflect the current state.

Address	Access	Description
00101.....	Read Only.....	System Stopped (0) / Running (1)
00102.....	Read Only.....	Verometer Not-Filling (0) / Filling (1)
00103.....	Read Only.....	Not in Standby (0) / Standby (1)
00104.....	Read Only.....	Memory Module Invalid (0) / Valid (1)
00105.....	Read Only.....	Z-65 Backup Disabled (0) / Enabled (1)
00106.....	Read Only.....	English (0) / Metric (1)
00107.....	Read Only.....	Proportional to Time (0) / Proportional to Flow (1)
00108.....	Read Only.....	Analog (0) / Pulse (1)
00109.....	Read Only.....	Linear (0) / Non-Linear (1) or Pulses/Sec (0) / Pulses/Min (1)<-Gas PPMV(1)<-LPG
00110.....	Read Only.....	Gas (0) / Liquid (1)
00111.....	Read Only (L).....	No Power-Up (0) / Power-Up (1) since last coil read
00112.....	Read Only.....	Odorant Tank Low Alarm Enabled (0) / Disabled (1)
00113.....	Read Only.....	Signal Alarms Enabled (0) / Disabled (1)
00114.....	Read Only.....	Verometer Alarms Enabled (0) / Disabled (1)
00115.....	Read Only.....	Pump Alarms Enabled (0) / Disabled (1)
00116.....	Read Only.....	Battery Alarm Enabled (0) / Disabled (1)
00117.....	Read Only (L).....	No Parm Change (0) / Parm Change (1) since last coil read
00118.....	Read Only.....	Normal (0) / No Flow Standby (1)
00119.....	Read Only.....	Normal (0) / Remote Inhibit (1)
00120.....	Read Only (L).....	New HOU/FLOW Data Available
00121.....	Read Only.....	No Load Cycle (0) / Load Cycle Active (1) – Liquid System Only

APPENDIX B: N-300 MODBUS SPECIFICATIONS

Alarm Functions

The alarm functions available via Modbus are listed below. The registers are accessed using Modbus function 1. All the alarms are latching and provide a “since the last read” output where a set condition will hold it’s state until a read of that particular register was made by the master device. Once a read is made, the alarm will reflect the current state.

Address	Access	Description
01001.....	Read Only.....	Global Alarm (1) (set if any alarm condition exists)
01002.....	Read Only.....	Pump Failure Alarm (1)
01003.....	Read Only.....	Over Pump Alarm (1)
01004.....	Read Only.....	Under Pump Alarm (1)
01005.....	Read Only.....	Verometer Cable Alarm (1)
01006.....	Read Only.....	Verometer Slow Fill Alarm (1)
01007.....	Read Only.....	Verometer No Fill Alarm (1)
01008.....	Read Only.....	Verometer Over Fill non-Alarm (1)
01009.....	Read Only.....	Verometer Leakage Alarm (1)
01010.....	Read Only.....	Verometer Fill Valve Alarm (1)
01011.....	Read Only.....	Verometer Fill Rate non-Alarm (1)
01012.....	Read Only.....	Signal Low Flow non-Alarm (1)
01013.....	Read Only.....	Signal No Flow non-Alarm (1)
01014.....	Read Only.....	Signal Overflow non-Alarm (1)
01015.....	Read Only.....	Signal Overflow Alarm (1)
01016.....	Read Only.....	Signal Loss of Signal Flow Alarm (1)
01017.....	Read Only.....	Low Battery Alarm (1)
01018.....	Read Only.....	External Tank level High Alarm (1)
01019.....	Read Only.....	External Tank level Low Alarm (1)
01020.....	Read Only.....	Expansion Tank Pressure High Alarm (1)
01021.....	Read Only.....	Expansion Tank Pressure Low Alarm (1)
01022.....	Read Only.....	Expansion Tank Pressure Cable Alarm (1)
01023.....	Read Only.....	Odorant Inlet Pressure High Alarm (1)
01024.....	Read Only.....	Odorant Inlet Pressure Low Alarm (1)
01025.....	Read Only.....	Odorant Inlet Pressure Cable Alarm (1)

APPENDIX B: N-300 MODBUS SPECIFICATIONS

Integer Registers

The integer data type could be used for the Results data and configuration/control parameters. The “holding registers” as referred to by the Modbus specification, are read/write registers. This 16-bit integer data type can be manipulated using functions 3, 6, and 16.

Function 3, allows the host to read one or more holding registers per query.

Function 6, allows the host to write a single holding register per query.

Function 16, allows the host to write multiple holding registers per query.

Result Data Functions

The result data functions available via Modbus are listed below. The registers are accessed using Modbus function 3.

Address	Access	Description
40001.....	Read Only.....	HOU/LOU – Accum. Odorant Usage – High - Unsigned integer *See formatting info.
40002.....	Read Only.....	HOU/LOU – Accum. Odorant Usage – Low - Unsigned integer *See formatting info.
40003.....	Read Only.....	HOU/LOU - Accumulated Flow rate – High - Unsigned integer *See formatting info.
40004.....	Read Only.....	HOU/LOU - Accumulated Flow rate – Low - Unsigned integer *See formatting info.
40005.....	Read Only.....	HOU/LOU Start Date (Day of Month/Month) (1-31/1-12) - BCD
40006.....	Read Only.....	HOU/LOU Start Date (Century/Year) (0000-9999) - BCD
40007.....	Read Only.....	HOU/LOU Start Time (Seconds/Minutes) (00-59/00-59) - BCD
40008.....	Read Only.....	HOU/LOU Start Time (Hours/Day of Week) (00-23/0-7) - BCD
40009.....	Read Only.....	HOU/LOU End Date (Day of Month/Month) (1-31/1-12) - BCD
40010.....	Read Only.....	HOU/LOU End Date (Century/Year) (0000-9999) – BCD
40011.....	Read Only.....	HOU/LOU End Time (Seconds/Minutes) (00-59/00-59) – BCD
40012.....	Read Only.....	HOU/LOU End Time (Hours/Day of Week) (00-23/0-7) – BCD
40013.....	Read Only.....	Stroke Count High (0000-9999) – BCD
40014.....	Read Only.....	Stroke Count Low (0000-9999) – BCD
40015.....	Read Only.....	Total Odorant Injected High (0000-9999) – BCD *See formatting info.
40016.....	Read Only.....	Total Odorant Injected Low (0000-9999) – BCD *See formatting info.
40017.....	Read Only.....	Model Number – Unsigned Integer *See formatting info.
40018.....	Read Only.....	Serial Number (xxxxx) – Unsigned Integer
40019.....	Read Only.....	Verometer Calibration Data – Unsigned Integer *See formatting info.
40020.....	Read Only.....	Odorant Tank Level (xxx %) – Unsigned Integer
40021.....	Read Only.....	Expansion Tank Pressure (xxx.x psi / x.xxx bar) – Unsigned Integer
40022.....	Read Only.....	Odorant Inlet Pressure (xxx.x psi / x.xxx bar) – Unsigned Integer
40023.....	Read Only.....	Calculated Time per Stroke High – Unsigned Integer – sec.
40024.....	Read Only.....	Calculated Time per Stroke Low – Unsigned Integer - (x.xx sec.)
40025.....	Read Only.....	Verometer Level (xxx.x %) – Unsigned Integer
40026.....	Read Only.....	Battery Voltage (xx.x volts) – Unsigned Integer

APPENDIX B: N-300 MODBUS SPECIFICATIONS

* Model Specific Formatting information for Result Data functions

Address	Description
40001.....	High bytes for Accumulated odorant injected, combine with address 40002 for total.
40002.....	6300GE/LE = .XXXXX, 7300GE/LE = X.XXXX, 8300GE/LE = XX.XXX (lbs), 6300GM/LM = .XXXXX, 7300GM/LM = X.XXXX, 8300GM/LM = XX.XXX (kg) Note: Low bytes only, combine with address 40001 for total odorant injected.
40003.....	High bytes for Accumulated flow, combine with address 40004 for total.
40004.....	6300GE = .XXXXX, 7300GE = X.XXXX, 8300GE = XX.XXX (MMCF/hr), 6300GM = X.XXX, 7300GM = XX.XXX, 8300GM = XXX.XX (M ³ /sec) 6300LE = XXX.XX, 7300LE = XXXX.X, 8300LE = XXXXX (gallons), 6300LM = XXX.XX, 7300LM = XXXX.X, 8300LM = XXXXX (liters), 6300/7300/8300LE (PPMV mode) = XXXXX (gallons), 6300/7300/8300LM (PPMV mode) = XXXXX (liters) Note: Low bytes only, combine with address 40003 for total accumulated flow.
40015.....	High bytes only, combine with address 40016 for total odorant injected.
40016.....	6300 = .XXXX, 7300 = X.XXX, 8300 = XX.XX (lbs/kg) Note: Low bytes only, combine with address 40015 for total odorant injected.
40017.....	Model number format: 63XX = 6300, 73XX = 7300, 83XX = 8300. XX= 11= GE, XX=12=GM, XX=21=LE, XX=22=LM. Example: 6311 = 6300 Gas English, 7322 = 7300 Liquid Metric
40019.....	6300 = XX.XXX, 7300 = XXX.XX, 8300 = XXXX.X (cc)

Parameter functions

The result data functions available via Modbus are listed below. The registers are accessed using Modbus functions 3, 6, and 16.

Note: The system must be stopped in order for any parameter changes to be accepted. An exception response will be returned if a parameter change query is issued while the system is running. Once the parameter changes have been made, use coil 00009 to save the updated parameters before restarting the system.

Address	Access	Description
40101.....	Read Only.....	Current Date (Day of Month / Month) (01-31 / 01-12) – BCD
40102.....	Read Only.....	Current Date (Century / Year) (0000-9999) – BCD
40103.....	Read Only.....	Current Time (Seconds / Minutes) (00-59 / 00-59) – BCD
40104.....	Read Only.....	Current Time (Hours / Day of Week) (00-23/01-07) – BCD
40105.....	Read/Write.....	Injection Rate - Unsigned Integer *See formatting info.
40106.....	Read/Write.....	Pump Displacement (cc/Stroke) – Unsigned Integer *See formatting info.
40107.....	Read/Write.....	Odorant Density – Unsigned Integer X.XX (GE/LE = lbs/gal, GM/LM = g/cc)
40108.....	Read/Write.....	Proportional to Time Stroke Rate X.XX (minutes) – Unsigned Integer
40109.....	Read/Write.....	Maximum Gas Flow – Unsigned Integer *See formatting info.
40110.....	Read/Write.....	Low Flow Shutoff (xx.x of Max Gas Flow) – Unsigned Integer
40111.....	Read/Write.....	Flow No Signal (xx.x of Max Gas Flow) – Unsigned Integer
40112.....	Read/Write.....	Maximum time per stroke (xxx minutes/stroke) – Unsigned Integer
40113.....	Read/Write.....	Odorant Output (lbs/pulse) – Unsigned Integer *See formatting info.
40114.....	Read/Write.....	Pulses per Second (xx Pulses/Seconds) – Unsigned Integer
40115.....	Read/Write.....	Pulses per Minute / Pulses per Gallon (xx Pulses/Minute - Gas, xx Pulses/Gal– Liquid PPMV) – Unsigned Integer

APPENDIX B: N-300 MODBUS SPECIFICATIONS

Parameter functions, *Continued*

40116..... Read/Write..... Odorant Tank Level High (xx %) – Unsigned Integer
40117..... Read/Write..... Odorant Tank Level Low (xx %) – Unsigned Integer
40118..... Read/Write..... Expansion Tank Pressure High (xx.x psi / x.xxx bar) – Unsigned Integer
40119..... Read/Write..... Expansion Tank Pressure Low (xx.x psi / x.xxx bar) – Unsigned Integer
40120..... Read/Write..... Odorant Inlet Pressure High (xx.x psi / x.xxx bar) – Unsigned Integer
40121..... Read/Write..... Odorant Inlet Pressure Low (xx.x psi / x.xxx bar) – Unsigned Integer

* Model Specific Formatting Information for Parameter functions

Address 40105: **GE = X.XX (lbs/MMCF)**
 GM = XXX.X (mg/m³)
 LE = X.XX (lbs/10K gal)
 LM = XXX.X (mg/liter)

Address 40106: **6300 = X.XXXX, 7300 = X.XXX, 8300 = XX.XX (cc/stroke)**

Address 40109: **6300GE = X.XXXX, 7300/8300GE = XX.XXX (MMCF/hr)**
 6300GM = XX.XXX, 7300/8300GM = XXX.XX (m³/sec)
 6300LE = XXXX.X, 7300/8300LE = XXXXX (gal/min)
 6300LM = XXXX.X, 7300/8300LM = XXXXX (liter/min)

Address 40113: **6300 = X.XXXX, 7300 = X.XXX, 8300 = X.XX (English = lbs/pulse, Metric = kg/pulse)**

Exception Responses

Exception responses are a means for the Slave device to indicate to the Master device that a query received could not be acted upon for a particular reason. Below is a listing of Exception codes.

Exception Code	Name/Description
1.....	Illegal Function: Function received in the query is not supported by the slave
2.....	Illegal Data Address: Data address received in the query is not supported by the slave
3.....	Illegal Data Value: Value contained in the query data field is not supported by the slave
4.....	Slave Device Failure: An unrecoverable error occurred while performing this action
5.....	Acknowledge: Query being processed but needs some time to complete
6.....	Slave device busy: Slave cannot process an incoming query at this time
7.....	Negative Acknowledge: Slave cannot perform the program function received
8.....	Memory parity error: A memory parity error occurred in the slave read attempt

APPENDIX C: RESPONSE FORMS

For the Record

To assist in trouble shooting, if required, please record the following information as the NJEX 6300G is initialized for the first time.

Basic information on the NJEX-6300G

- Serial number: _____
- N-300G version (x.xx): _____
- Manufacturing date: _____
- Date of Start up: _____
- Technician's Name: _____

Location

- Site ID: _____
- Startup Technician: _____
- Site Telephone: _____

Conditions

- Pipeline Pressure: _____
- Expansion Tank Pressure: _____
25 psi (1.72 Bar) expansion tank pressure is required.
- Bulk Tank: _____
30-35 psi (2.07-2.41 Bar) bulk tank pressure range is required.
- Supply Actuation Pressure: _____
75 psi (5.17 Bar) supply actuation pressure is required.
- Pump Actuation Pressure: _____
Refer to System Schematic Illustration, Table 1, page 10 for required pressures.
- Gas Flow Rate: _____
Record in MMCF/hr or m3/sec.
- Bulk Odorant Storage Level: _____
- Ambient Temp Range: _____
- Pump Stroke Volume: _____
Record in cc/stroke

Parameters

- Injection Rate: _____
- Pump Displacement: _____
- Odorant Density: _____
- Max Gas Flow: _____
- Low Flow Shutoff: _____
- Flow (no signal): _____
- Max Time/Stroke: _____
- Odorant Output: _____

Run Mode

Select One

___ Proportional-to-Time

___ Proportional-to-Flow

If Proportional to-Flow, select one

___ Analog-Linear

___ Analog-Non-Linear

___ Pulses-per-Second

___ Pulses-per-Minute



NJEX TROUBLE SHOOTING FORM

ReturnTo: F: 281.362.6513
Em: TechSupport@yzhq.com

NJEX-6300G (serial number/N-300G version x.xx/mfg. date): _____

Date: _____ Your Name: _____

LOCATION:

Site ID: _____

Attending Technicians: _____

Telephone: _____

CONDITIONS:

Pipeline Pressure: _____

Expansion Tank (25 psi) (1.72 Bar): _____

Bulk Tank (30-35 psi) (2.07-2.41 Bar): _____ cc/stroke: _____

Supply Actuation (75 psi) (5.17 Bar): _____

Pump Actuation (See Flow Chart for pressure): _____ meter level: _____

Gas Flow Rate (MMCF/hr) (m3/sec.): _____

Bulk Odorant Storage Level: _____ flow input: _____

Ambient Temp Range: _____

Date of Last Problem (mm/yr): _____ battery VDC: _____

PARAMETERS:

Injection Rate: _____ **RUN MODE:**

Pump Displacement: _____ Proportional-To-Time _____ Proportional-To-Flow _____

Odorant Density: _____ Analog _____

Max Gas Flow: _____ Linear _____

Low Flow Shutoff: _____ Non-linear _____

Flow (no signal): _____ Pulses _____

Max Time/Stroke: _____ PPS _____

Odorant Output: _____ PPM _____

ALARMS:

Pump

- ___ Overpumping
- ___ Underpumping
- ___ Pump Failure

Verometer

- ___ Slow Fill
- ___ No Fill
- ___ Vmtr-Cable
- ___ FLValve-Fail
- ___ Leakage
- ___ Odorant Inlet Cable
- ___ Odorant Inlet Low
- ___ Odorant Inlet High
- ___ XTank Cable
- ___ XTank Low
- ___ XTank High

Signal

- ___ Low Flow
- ___ Over Flow
- ___ Loss of Signal

Tank

- ___ Low Level
- ___ High Level

Battery

- ___ Low Battery

APPENDIX D: DOCUMENTS

N-300 Controller Display Diagram, Figure 212

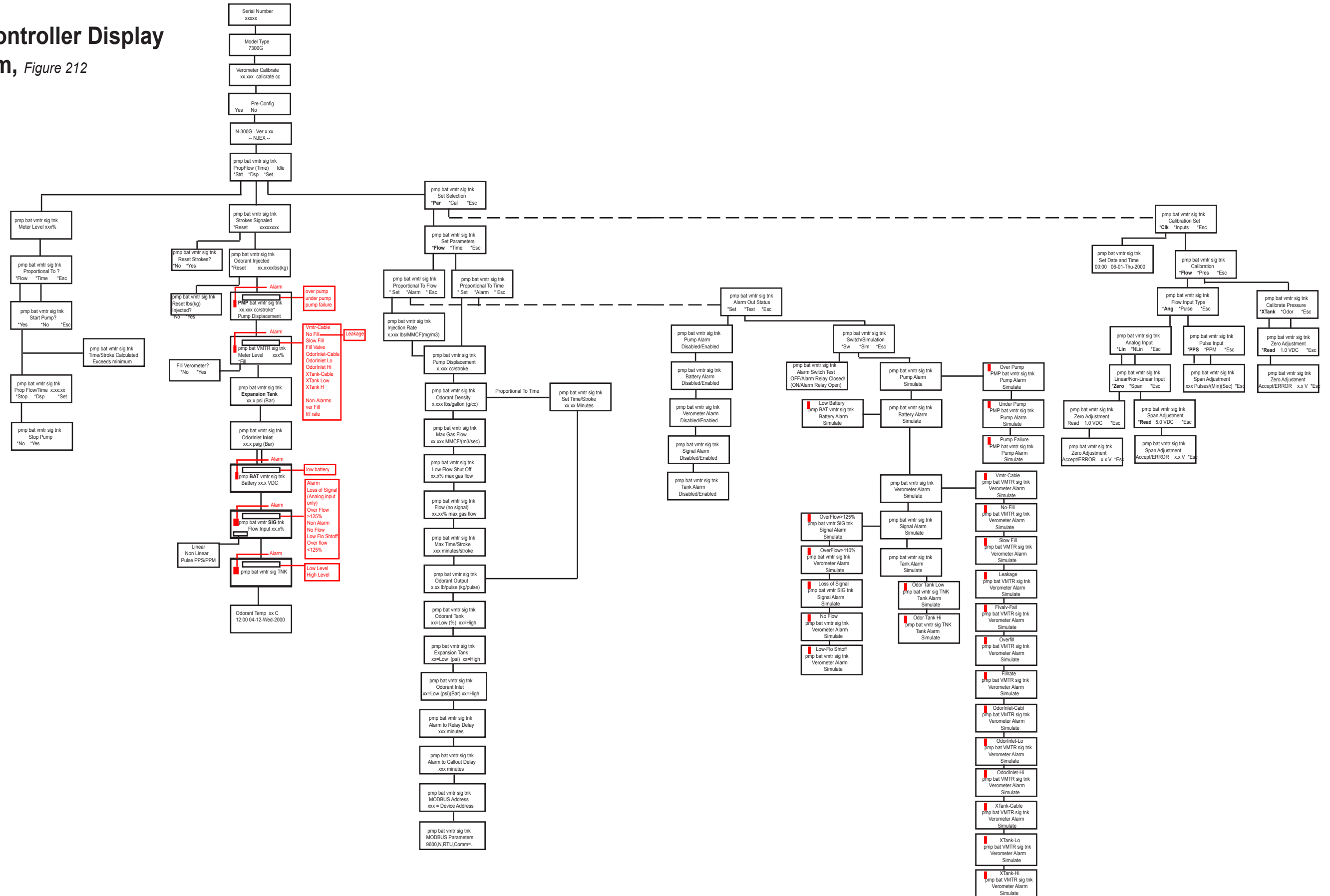

APPENDIX D: DOCUMENTS

1E-0345.dwg ()

Wiring Control Document Figure 213

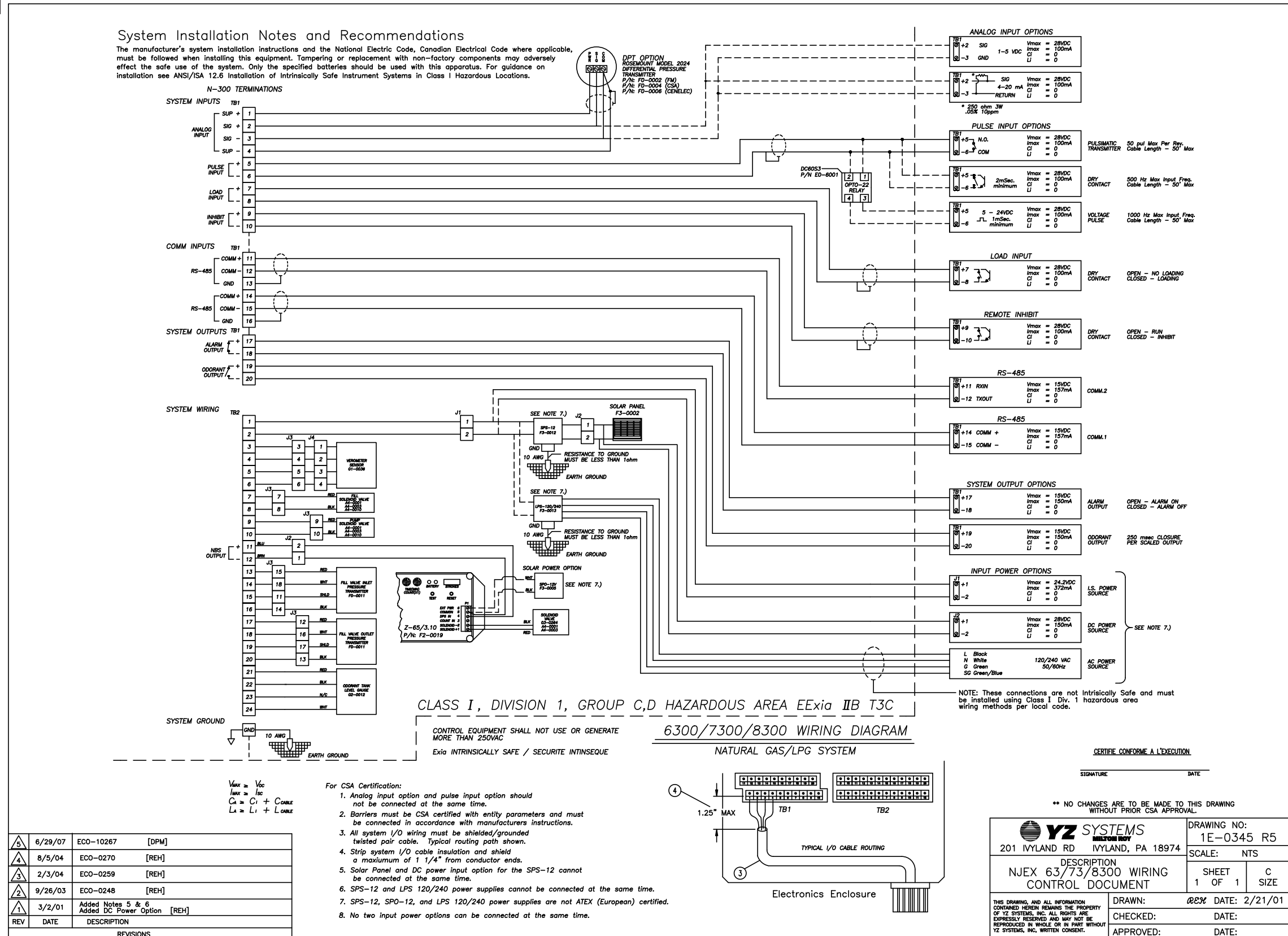



201 Ivyland Road

Ivyland, PA 18974

P: 281.362.6500

F: 281.362.6513

TechSupport@yzhq.com

www.yzsystems.com